

**PRESENTING
USING
THE
NOMAD
PRESENTATION STATION**

**CBA Computing Services
College of Business
UIC**

Contents

Basic

1	Present using the Nomad in 5 easy steps	
	Powerpoint Presentation 2
	Papers, Books and Magazines 4
	DVD / VHS Video 6
	Using a Laptop 8

Powerpoint
Presentation

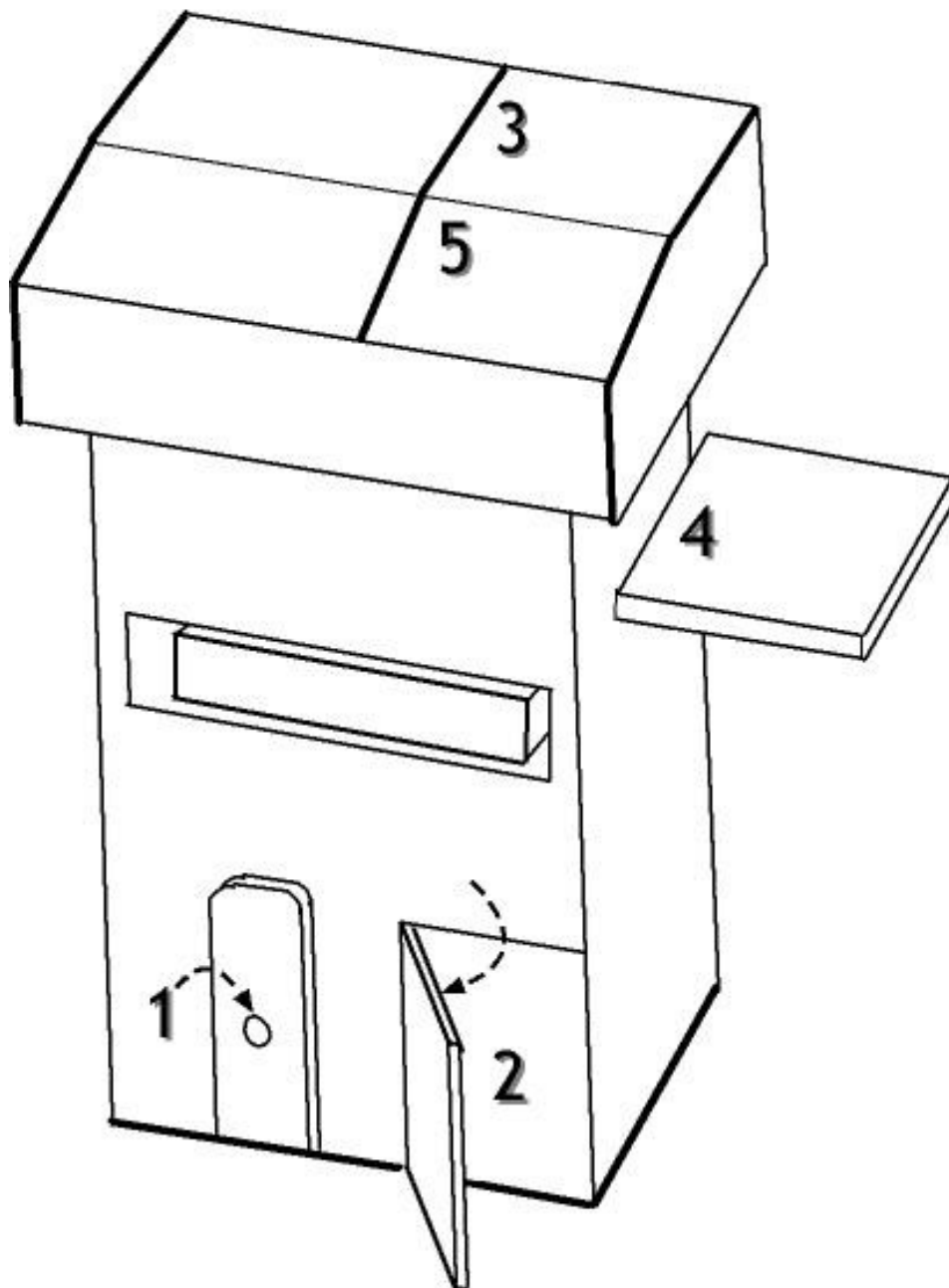
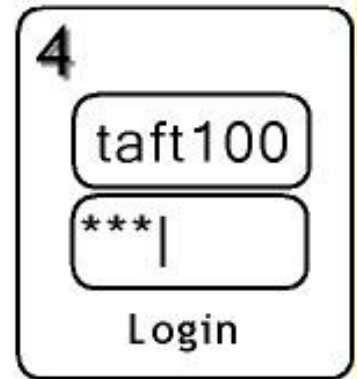
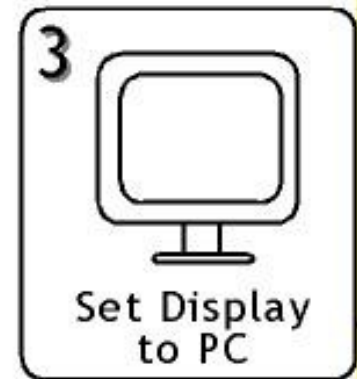

Powerpoint Presentation (Using the PC)

5 easy steps

Step 1: **Power on the PC** as indicated in the diagram

Step 2: **Open the podium's bottom corner door** as indicated and take the keyboard and mouse

Step 3: **Press the “PC” button** to switch the display at the indicated part of the podium

Step 4: **Login** using username: **taft100**
password: *****|
domain: **CBA**

Step 5: **Start the slideshow** by opening your presentation.

5 steps didn't help.. now what?

Some FAQs to help.

- * If your presentation is on a USB/Flash drive just plug it into the USB socket found in front of the PC (marked '1' in the diagram). You should be able to see the presentation in one of the drives in “My Computer” in a minute or two.
- * If your presentation is in your e-mail, just open Internet Explorer and login to your e-mail account. Then download your presentation onto the desktop. Now you are ready to go.

Wrapping up after presentation.

- * Shutdown the system from windows.
- * Replace the mouse and keyboard securing them in their cabinet.
- * Power down the PC.

VHS or DVD
Video

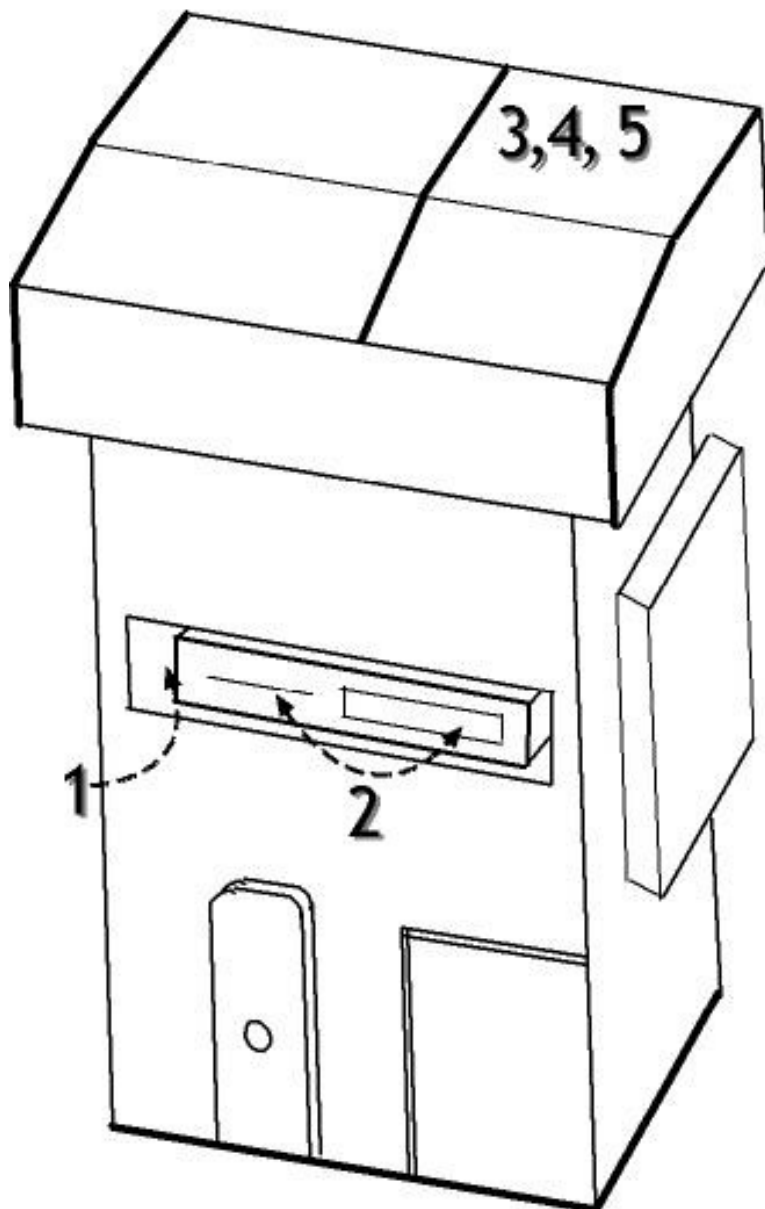
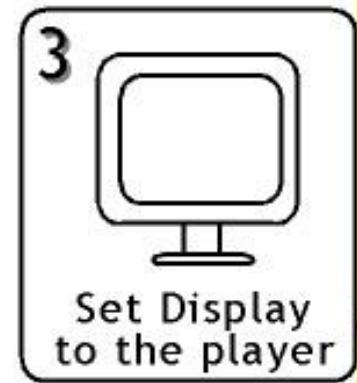

Playing DVD/VHS Video (Using the DVD/VHS Player)

5 easy steps

Step 1: **Power on the DVD/VHS player**

Step 2: **Insert the DVD/VHS video** as indicated

Step 3: **Press the “DVD” or “VCR” button** to switch the display at the indicated part of the podium (on the control panel) as needed.

Step 4: **Play the video** using the same controls

Step 5: You can **control the volume** using the same controls

5 steps didn't help.. now what?

Some FAQs to help.

- * You can also control the video using the buttons using smaller buttons in front of the player
- * You can switch between VCR / DVD using either the control panel on the top of the podium (marked “3, 4, 5”) in the diagram or the button in the player itself. (It is just between 'Channel ^' and 'EZ View').
- * Other instructions on what might happen if you press some buttons on the control panel are provided in the control panel itself.

Wrapping up after presentation.

- * Stop the video.
- * Remove the DVD/VHS from the player.
- * Power down the DVD/VHS player.

Papers, Books & Magazines

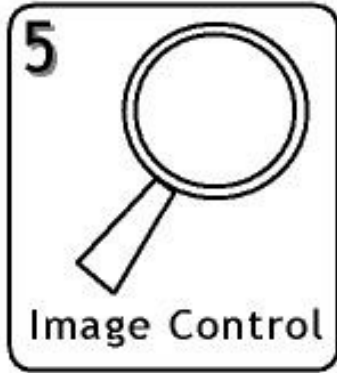
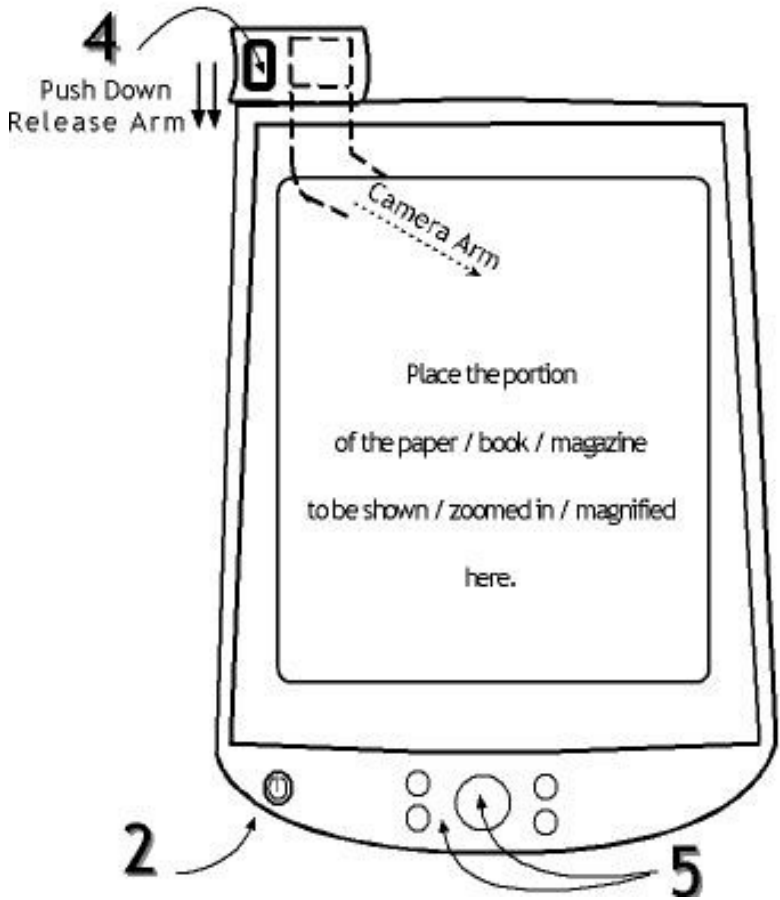
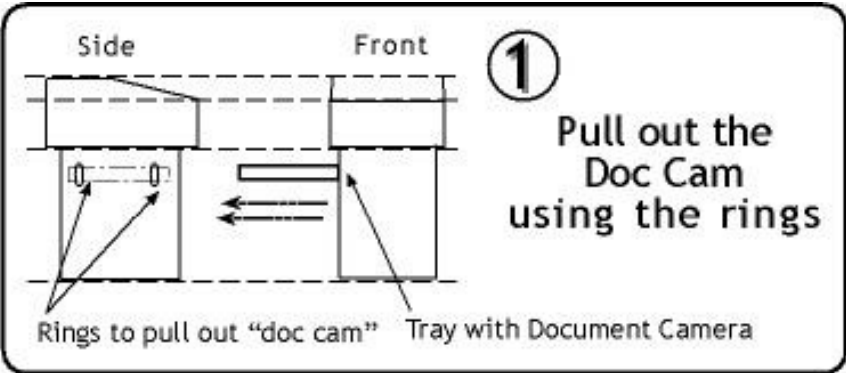

Books, Magazines & Paper (Using the Doc Cam)

(or any application that needs a powerful camera)

5 easy steps

Step 1: **Pull out the Doc Camera** as indicated in the diagram

Step 2: **Power on the Doc Cam** as shown

Step 3: **Press the “Doc Cam” button** to switch the display at the indicated part of the podium

Step 4: **Press down & forward as indicated** and release the camera and arm. (Do not forget to remove the cap from the camera and handle the arm gently while adjusting)

Step 5: **Zoom in, Zoom out and manipulate** captured image in whichever way is pleasing.

5 steps didn't help.. now what?

Some FAQs to help.

- * Autofocus is always set, so that as you zoom in the image resolves itself to a sharp image. But, in case it is off, you can switch it on using the “AF” button.
- * You can rotate images by pressing “ROTATE”.
- * “LAMP” button – turns on the lamp (particularly useful for transparent sheets). Think of this as an improvised overhead projector.
- * “IRIS + / -” will let you focus manually. For best results you should first switch off “AF” if it is already on (by default AF is On).

Wrapping up after presentation.

- * Reset the camera after replacing the cap to the rest position.
- * Power down the Doc Camera.
- * Remove presented materials from the flat bed of the doc cam.
- * Push tray slowly into the podium.

Presenting with a laptop

1



Take VGA Cable

2



Connect cable to laptop

3



Set Display to notebook

4



Set Display from Notebook

5



Start the Slideshow

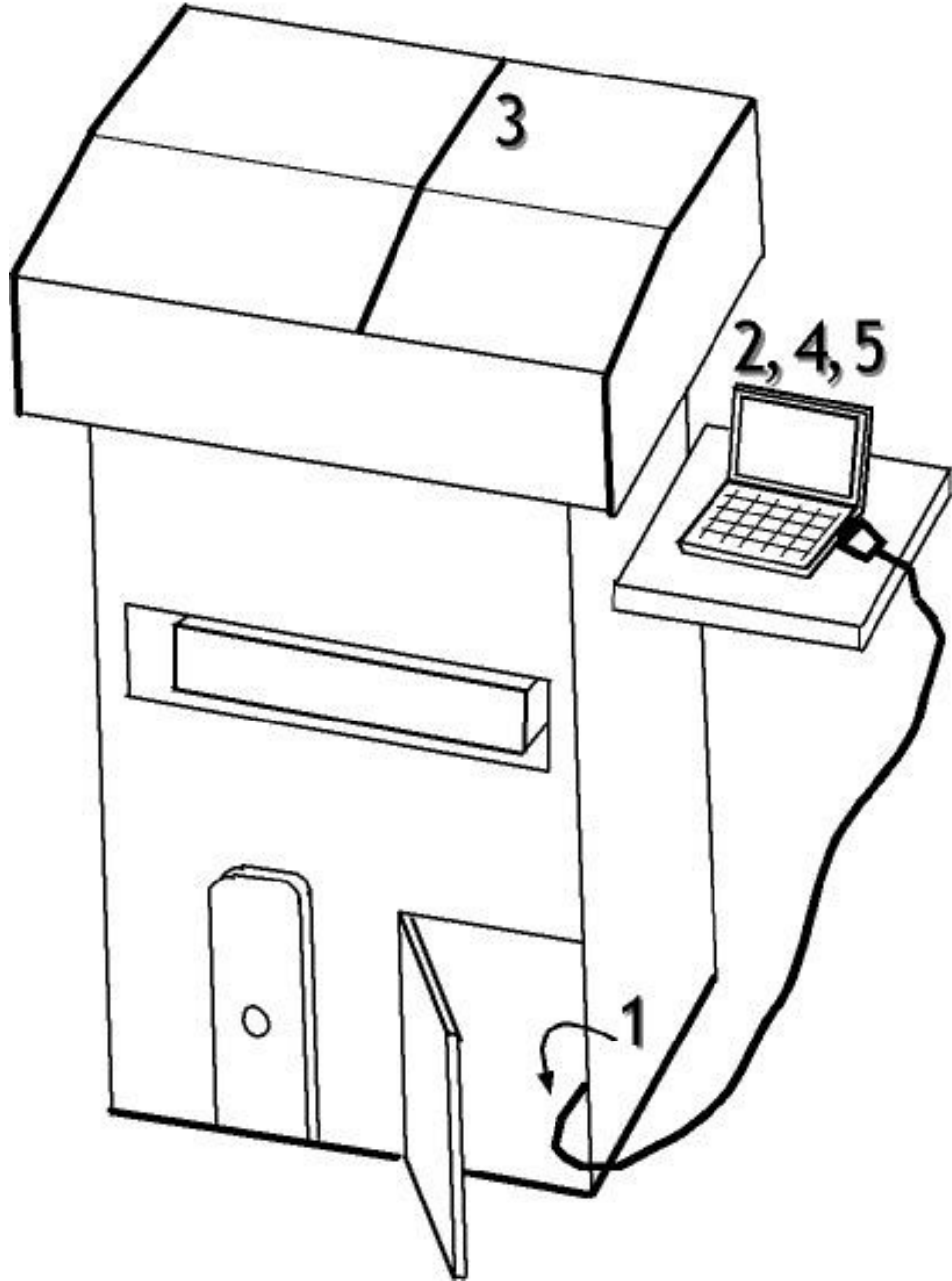

Using a Laptop PC

5 easy steps

Step 1: **Take the VGA cable** from the right bottom corner of the podium

Step 2: **Plug it into** the Laptop's VGA outlet

Step 3: **Switch the display to “NTBK”** by pressing the appropriate button at the indicated area

Step 4: **Switch to the display** using “Fn + F7” (or whichever combination works) **from the laptop**

Step 5: **Start the slideshow or any application/video** from the laptop

5 steps didn't help.. now what?

Some FAQs to help.

- * If you are using the laptop provided in Taft Hall, use the combination lock and unlock the white box next to the podium.
- * To plug in power for any laptop use the provided outlet in the side of the podium.
- * Make sure you have switched both the displays :-
 1. The appropriate function key from the laptop
 2. The “NTBK” key on the control panel
- * For sound you will need to connect the audio cable to the laptop too.

Wrapping up after presentation.

- * **Important:** Switch back to normal mode on the laptop before unplugging the VGA cord
- * Make sure the laptop is switched back to normal display mode and unplug the VGA cord
- * Replace VGA cable and audio cable in the designated area.
- * If you are using the laptop in Taft Hall, make sure you securely lock the laptop in the designated white box.