

GENERAL PRINCIPLES OF DRUG DISPOSITION AND PHARMACOKINETICS

I. Routes of Administration.

Enteral	Special Utility	Limitations/Risks
Oral (p.o.)	#Easy #Usually safe #Economical	#Relatively slow #Less predictable #First pass effect #Patient compliance
Sublingual	#Rapid response #No first pass effect #Bypasses gi acids and enzymes	#Many molecules do not penetrate oral mucosa #Not used for irritating substances
Rectal	#Unconscious patients #Vomiting patients #Small children #Minimal first pass effect #Bypasses gi acids and enzymes	#Irregular and incomplete absorption #Not used for irritating substances #Solutions must be isotonic
Parenteral	Special Utility	Limitations/Risks
Intravenous (i.v.)	#Most rapid response (emergencies) #Permits titration of dosage #Most suitable for irritating substances and large volumes #Lowest intra-individual variability	#Greatest risks: overdose, anaphylaxis, infection, embolism, vascular injury, extravasion
Intramuscular (i.m.)	#Moderate volumes #Faster absorption than s.c.	#Not used for irritating substances #Sterile abscesses #May interfere with diagnostic tests #Precluded during anticoagulant therapy
Subcutaneous (s.c.)	#Slower absorption than i.m. #Absorption slowed by vasoconstriction	#Not used for irritating substances #Large volumes are painful
Intraperitoneal (i.p.)	#Provides large absorbing surface #Primarily used on lab animals	#First pass effect #Risks: adhesions, infection, injury
Topical	#Useful for local effects #Poisons and toxins	#Least effective for systemic absorption
Intrathecal (i.t.)	#Local anesthetics/antibiotics #Bypasses BBB and blood-CSF barrier	#Risks: infection, headaches
Pulmonary	#Useful for gases, vapors, aerosols #Very rapid absorption	#Not used for irritating substances #Difficult to control dose

First Pass Effect:

- ! When a drug is administered orally, the drug is absorbed by the mesenteric veins. These veins drain into the portal vein which flows into the hepatic sinusoids. For some drugs, a **substantial portion of the dose** is removed and metabolized by the hepatocytes in its first pass through the liver before the drug enters the systemic circulation. Also evidence that significant first pass metabolism can occur in gi epithelial cells.
- ! The intraperitoneal route of administration may also demonstrate a significant first pass effect.
- ! The rectal route of administration demonstrates a minimal first pass effect, because the inferior rectal veins drain primarily into the inferior vena cava and bypass the liver.

If **equieffective** doses are administered, the following rank order describes the **speed of effect**.

IV > IM > SC > Oral

and the following rank order describes the **duration of the effect**:

Oral > SC > IM > IV

II. Absorption.

A. **Definition:** Movement of a drug from its site of administration to the systemic arterial circulation.

B. Movement of Drugs Across Membranes:

- # **Active Transport:** i) energy dependent; ii) saturable; iii) against an electrochemical gradient; iv) selective carrier-mediated.
- # **Facilitated Diffusion:** i) requires NO energy; ii) saturable; iii) NEVER against an electrochemical gradient; iv) selective carrier-mediated.
- # **Pinocytosis:** Drugs of large molecular weight (MW > 900) may enter cells by pinocytosis or phagocytosis.
- # **Passive Diffusion:** This is the **MOST COMMON** mechanism for drug transport. Lipid-soluble drugs permeate across the cell membrane by passive diffusion between the lipid molecules of the cell membrane.

C. Absorption of Drugs by the Gastrointestinal Tract:

- # **Epithelial Barriers to Drugs:** Epithelial cells in the GI are joined to one another by occluding zonulae (tight junctions). Drugs must pass THROUGH the cells and can not pass around the cells.
- # **Surface Area:** Larger surface areas absorb drugs faster than smaller ones. The gastric mucosa has villi, the small intestines have microvilli. Therefore, the intestines have a much greater surface area than the stomach. Most drugs can be absorbed by the intestines. **As a generalization**, the presence of food will slow

gastric emptying time and will slow the absorption of an orally administered drug. Also, **many drugs** slow gastric emptying and may slow the absorption of a second drug.

D. Chemical Factors That Affect **NON-IONIC PASSIVE DIFFUSION**:

- # Molecular size of the drug.
- # Solubility in water.
- # Concentration of the drug.
- # Oil/Water partition coefficient (K_p) of the drug.

$$K_p = \frac{C_{oil}}{C_{water}}$$

Where C_{oil} is the concentration of drug in the oil or organic phase, and C_{water} is the concentration of the drug in the water or aqueous phase

- # The extent of ionization (the pH of the environment and the pK_a of the drug).

$$pH - pK_a = \log \frac{UNPROTONATED FORM (R)}{PROTONATED FORM (RH)}$$

- # **Gastric absorption:** The pH of gastric juice is low (1 to 3). Weak bases will be ionized and will be poorly absorbed. Weak acids will be unionized and will be absorbed well. Furthermore, weak bases--even if they are administered IV--may cross the capillaries and the gastric mucosa and enter the gastric juice where they become ionized and **trapped**. They may be absorbed later when they reach the intestines.
- # **Intestinal absorption:** The pH of intestinal juice is more basic than gastric juice (5 to 6). Here most weak bases will be unionized and will be readily absorbed. In contrast, most weak acids will be ionized and will be poorly absorbed.

ABSORPTION OF A WEAK ACID (pKa = 4.4)

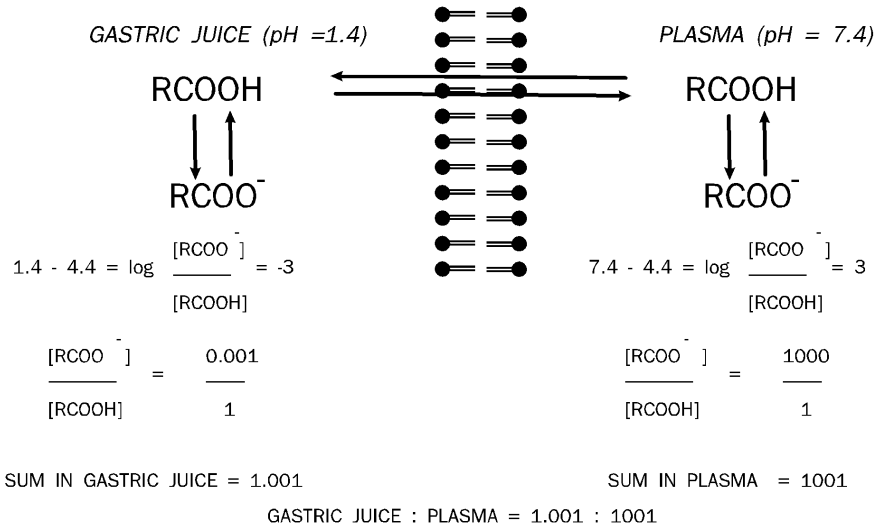

ABSORPTION OF A WEAK BASE (pKa = 4.4)

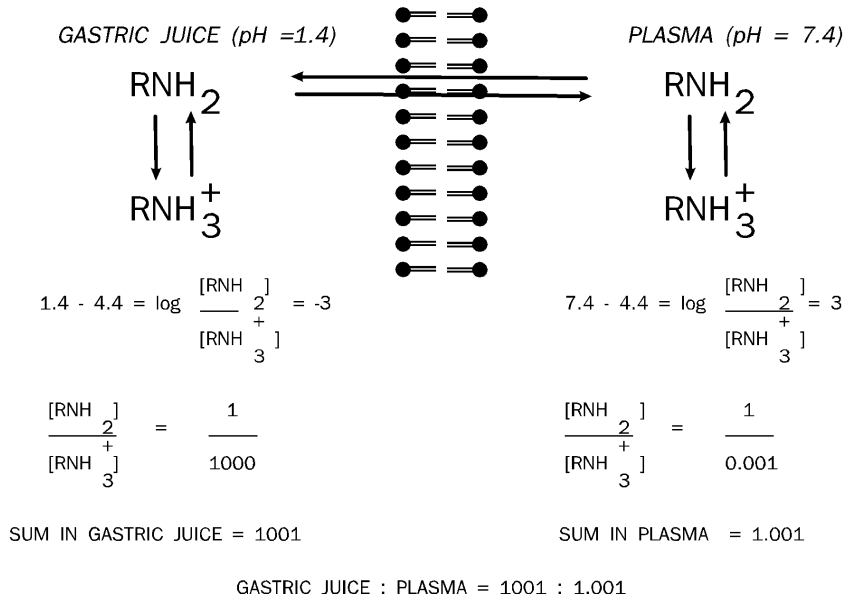

FORMULAS FOR CALCULATING THE RATIO OF DRUG CONCENTRATIONS IN TWO SEPARATE COMPARTMENTS

FOR AN ACID:

$$\frac{C_1}{C_2} = \frac{1 + 10^{(pH_1 - pK_a)}}{1 + 10^{(pH_2 - pK_a)}}$$

FOR A BASE:

$$\frac{C_1}{C_2} = \frac{1 + 10^{(pK_a - pH_1)}}{1 + 10^{(pK_a - pH_2)}}$$

Effect of pH on Gastric Absorption

Drug	pK _a	% Absorbed in 1 hour (pH = 1)	% Absorbed in 1 hour (pH = 8)
Acids			
5-sulfosalicylic acid	< 1	0	0
salicylic acid	3.0	61	13
thiopental	7.6	46	34
bases			
aniline	4.6	6	56
quinine	8.4	0	18

Effect of Partition Coefficient on Drug Absorption

<u>Barbiturate</u>	<u>pK_a</u>	<u>K_p (Hept/H₂O)</u>	<u>% Absorbed in 1 hour</u>
Barbital	7.8	0.001	4
Secobarbital	7.9	0.1	30
Thiopental	7.6	3.3	46

Bioavailability:

- # The **Bioavailable Fraction** (usually written **F**) is the percentile fraction of the total dose that enters the systemic circulation. With the IV route of administration 100% of the drug enters the systemic circulation and **F** is equal to 1. With the oral route, only a fraction of the total dose enters the systemic circulation, and the Bioavailable Fraction (**F**) is equal to that fraction.
- # One can compare the Bioavailable Fractions of two preparations, or of a single preparation under different conditions, by comparing the **areas under the curve** of plots of plasma drug concentration versus time.
- # **F** is not the only important parameter of bioavailability; maximal plasma levels or concentrations (**C_{max}**) can also vary for different pharmaceutical preparations. **C_{max}** predicts the degree of pharmacological (or toxicological) effect.
- # Two separate pharmaceutical preparations may contain the same amount of the same compound, but they may not exhibit identical bioavailability and may not yield identical plasma drug concentrations in the same patient.
- # The cardiac drug digoxin serves as a classic example. The figure below illustrates the serum digoxin levels obtained in four different patients (S.S., H.R., C.H., and M.B.) after oral administration of four different digoxin preparations (A, B₁, B₂, and C), each containing the same amount of drug. Each preparation produces distinct plasma levels and the areas under the concentration-time curves are different; each preparation has a different **bioavailability**.

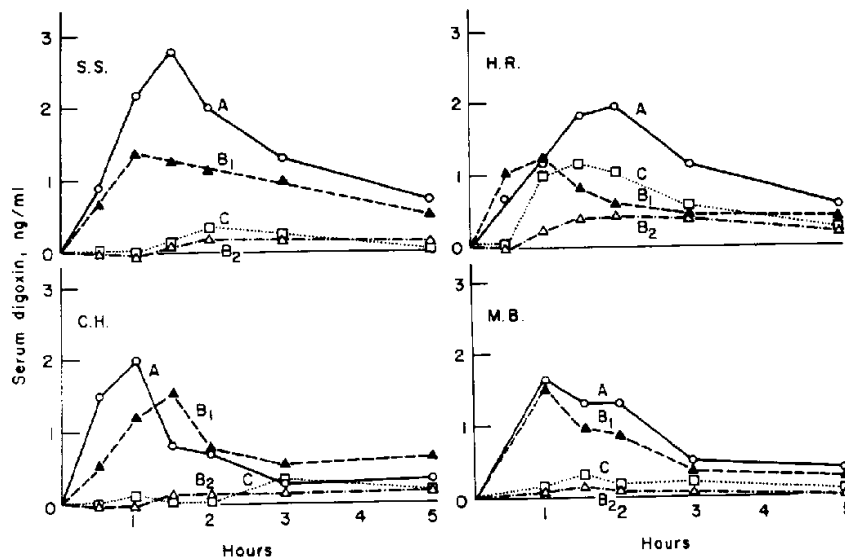

- # Factors that can affect bioavailability include: the size and type of the pill/capsule, the type of inert ingredients included in the preparation, and the crystalline properties and rates of dissolution of the drug itself.

III. Distribution.

A. Fluid Compartments

Typical Volumes of Fluid Compartments in a 70 Kg Man

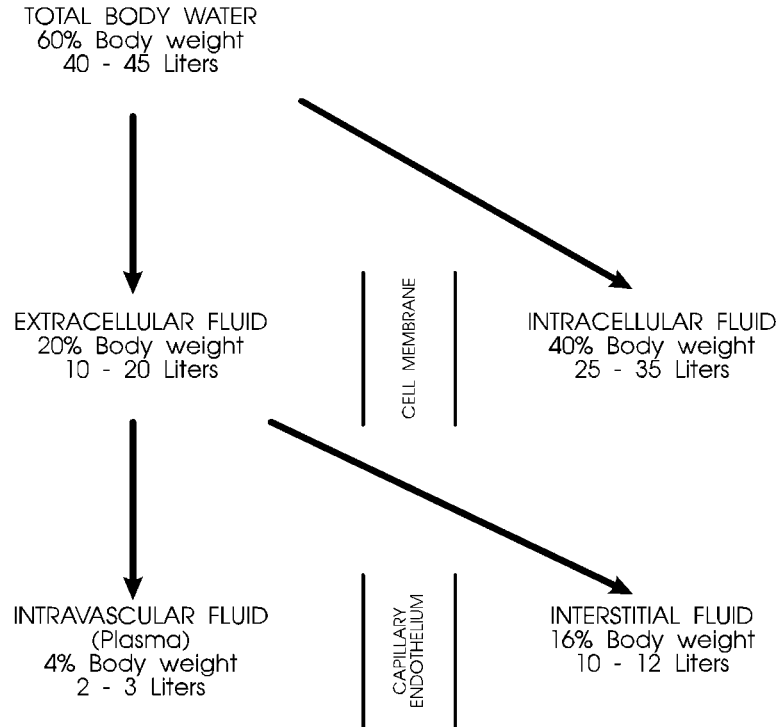

B. Apparent Volume of Distribution

$$V_d = \frac{\text{Amount in Body}}{\text{Plasma Conc.}} = \frac{\text{Initial Dose (D)}}{\text{Conc. at Zero Time (C}_{t_0}\text{)}}$$

Where "D" is the total **amount** of drug given initially, and "C_{t₀}" is the concentration of drug in plasma at zero time

Volume of distribution is the ratio between the dose and the plasma concentration at time zero (after mixing has occurred, but before the drug is cleared). It has units of liters or milliliters.

It is physically impossible to directly measure C_{t₀}. It can, however, be accurately *estimated* by extrapolating the latter portion of the concentration-time curve back to the Y-axis (i.e. to the point where t=0).

A common way of expressing V_d is as a "fractional V_d", which has units of liters/kg body weight. (Strictly speaking, this is a ratio rather than a volume). The "fractional V_d" compensates for differences in body weights. For example, if the fractional V_d for a drug is 0.6 l/kg, the V_d is (0.6 x 70) = 42 liters in a 70 kg patient, or (0.6 x 50) = 30 liters in a 50 kg patient.

C. Factors That Affect the Rate of Drug Distribution

- # Lipid solubility (K_p)
- # Degree of ionization
- # Molecular weight
- # Blood flow

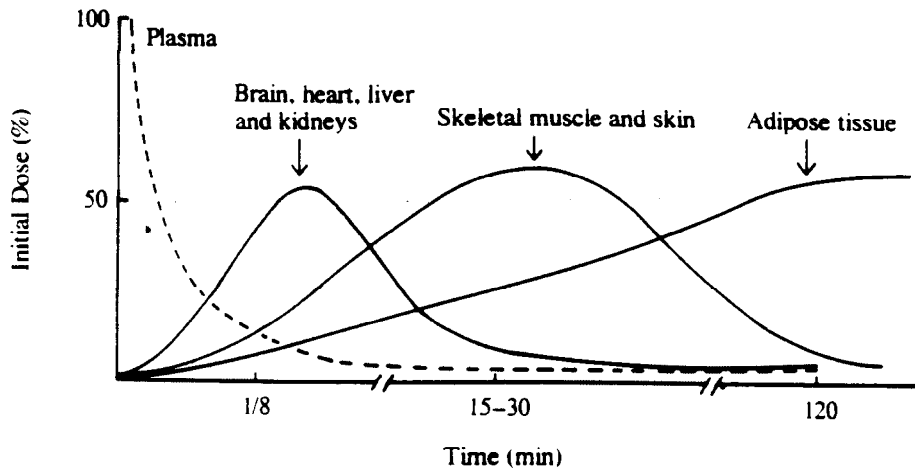

D. Factors That Affect the Extent of Drug Distribution

- # Lipid solubility (K_p)
- # Plasma protein binding
- # Tissue binding

E. Plasma Protein Binding

$$\text{Percent Drug Bound} = \frac{([D_{Total}] - [D_{Free}])}{[D_{Total}]} \times 100\%$$

F. Capillary Barriers to Drugs:

- # Capillaries with maculae ("spot junctions").
- # Fenestrated capillaries (kidney).
- # Capillaries with occluding zonulae (Blood-Brain Barrier)

F. Transport of Drugs Across the Placenta

Maternal-Fetal Equilibration of Tubocurarine and Thiopental

Time (min)	Maternal Tubocurarine	Fetal Tubocurarine	Maternal Thiopental	Fetal Thiopental
5	3	0	8.5	5.5
6	3.2	0	8	3.5
9	1.1	0.1	4.8	2.5
12	2.1	0.1	3	2

IV. Drug Metabolism

"Phase I" reactions: a change in the chemical structure of the drug molecule; oxidation, reduction, oxygenation, dealkylation, hydrolysis

"Phase II" reactions: combination (conjugation) of the drug molecule with a second endogenous substance; glucuronidation, sulfation, mercapturic acid formation (glutathione), acetylation, methylation, glycine conjugation

Net Result (Usually): Alteration of pharmacological activity (potentiation or deactivation), facilitation of excretion.

A. Phase I reactions

1) The Cytochrome P450 Monooxygenases (CYP)

The active site of cytochrome P-450:

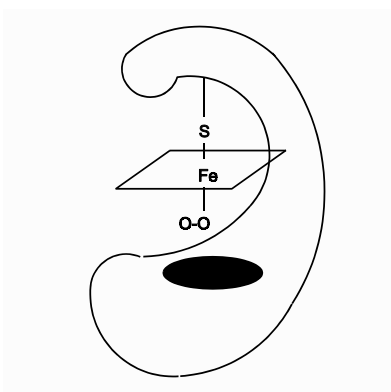

Steps of the reaction:

- #Drug substrate binds to P450
- #P-450-drug complex is reduced by NADPH
- #Molecular oxygen (O₂) binds to reduced P-450-drug complex
- #Oxygen is reduced to an "activated" state
- #One atom of oxygen combines with the drug substrate, the other atom forms water
- #The enzyme complex dissociates to yield free oxygenated drug metabolite

Stoichiometry of the reaction:

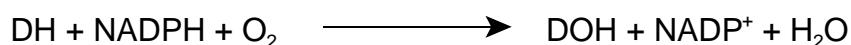

Where DH is the drug substrate and DOH is the oxygenated (in this case hydroxylated) drug metabolite

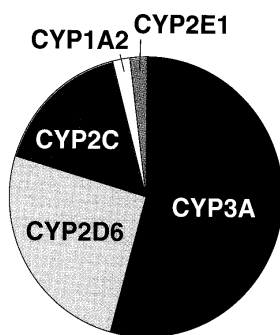

Figure 1-4. The proportion of drugs metabolized by the major cytochrome P450 enzymes.

#Inhibition of Cytochrome P450

- #Cimetidine
- #Quinidine
- #Ciprofloxacin
- #Ketoconazole
- #Erythromycin
- #Ethanol
- #Oral Contraceptives
- #Many others

#Induction of Cytochrome P450

- #Barbiturates
- #Phenytoin
- #Steroids
- #Polycyclic aromatic hydrocarbons
- #Ethanol
- #Isoniazid
- #Rifampicin

INCREASED METABOLISM OF ZOXAZOLAMINE AFTER PRETREATMENT WITH PHENOBARBITAL OR BENZO[A]PYRENE

Pretreatment	Duration of Paralysis	Zoxazolamine half-life
None	12 hours	9 hours
Phenobarbital	102 min	48 min
Benzo[a]pyrene	17 min	10 min

2) Individual Phase I Reactions

A. Oxidation Reactions Mediated by Cytochrome P450:

#Hydroxylation

Aliphatic (side chain) hydroxylation

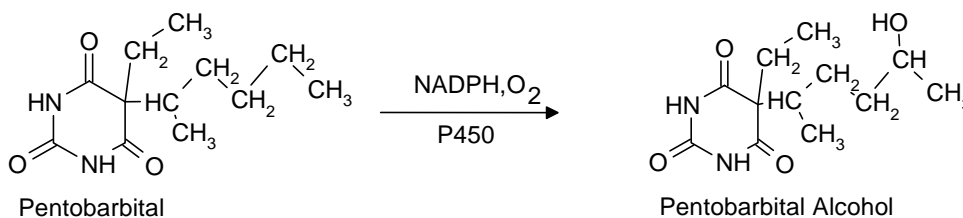

Aromatic hydroxylation

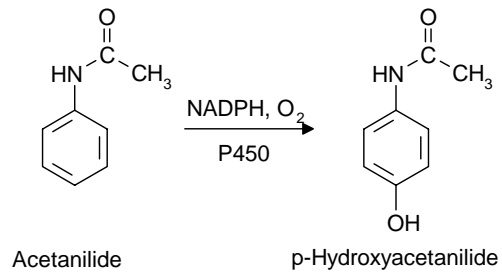

#Dealkylation

N-dealkylation (Secondary or Tertiary amines)

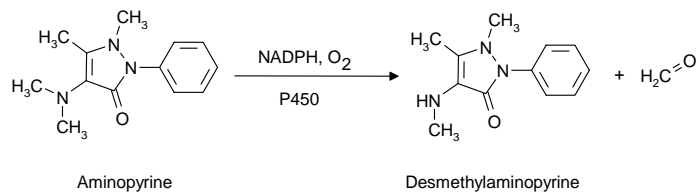

O-dealkylation (ethers)

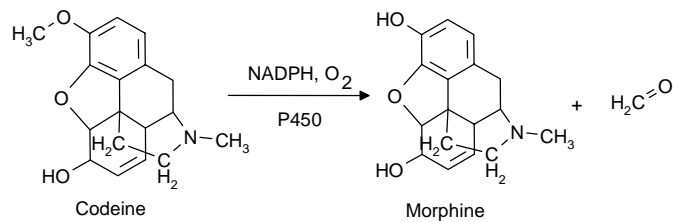

#Epoxidation

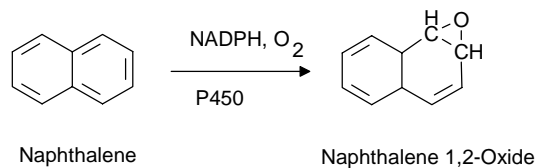

#Oxidative deamination

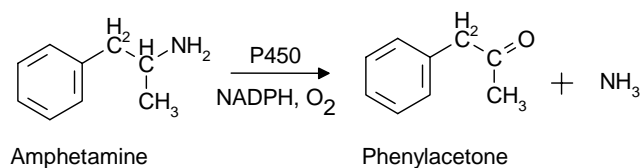

#N-oxidation

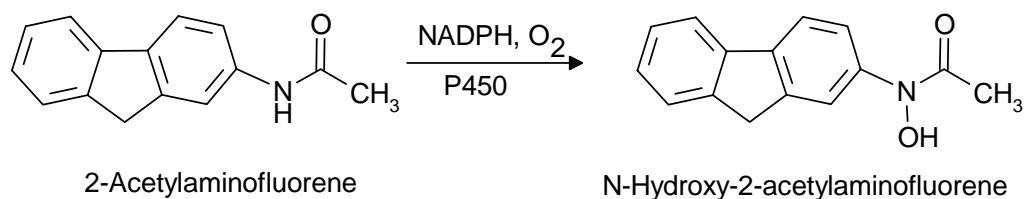

B. Oxidation Reactions Not Mediated By Cytochrome P450

#Alcohol and Aldehyde Oxidation

Alcohol dehydrogenase

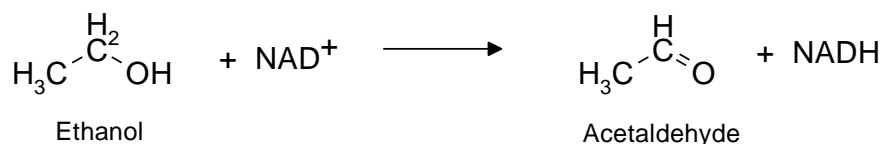

Aldehyde dehydrogenase

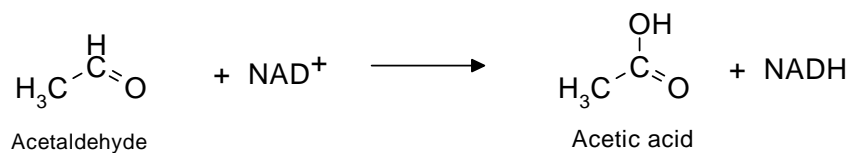

#Monamine Oxidase (MAO)

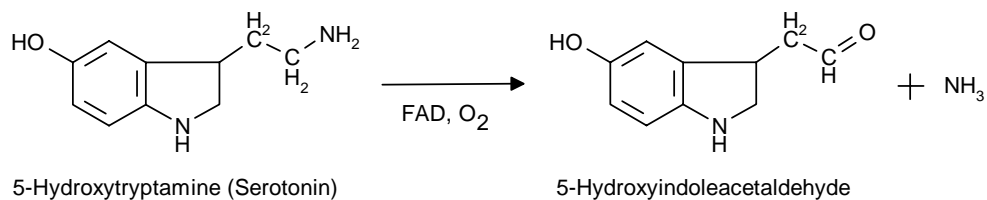

#Epoxides

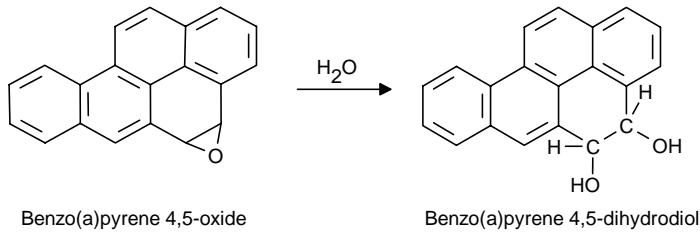

B. Individual Phase II Reactions (Conjugation Reactions)

1) Glucuronidation (carboxylic acids and alcohols or phenols)

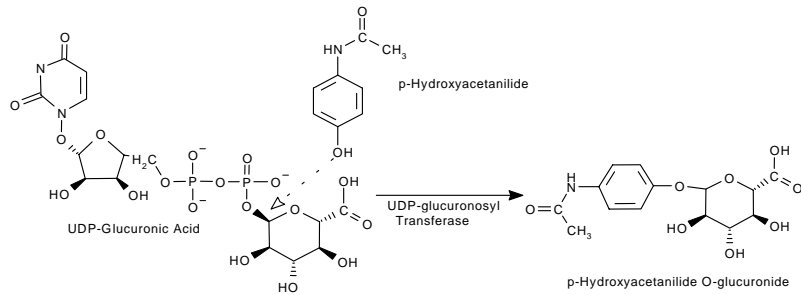
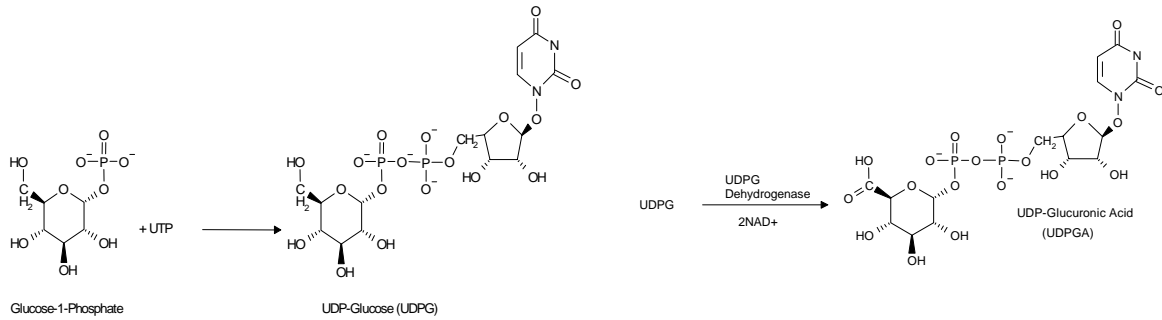

2) Sulfate Conjugation

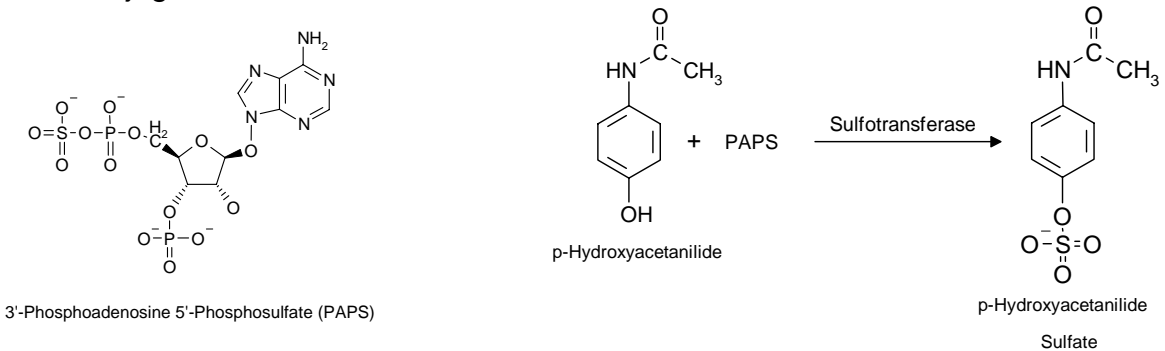

3) Acetylation

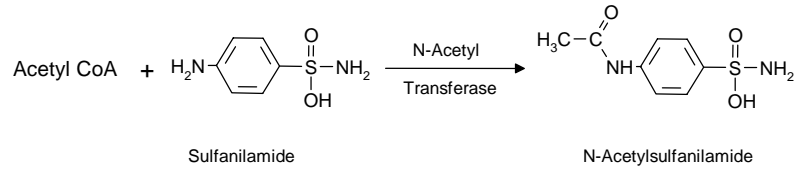

4) Amino Acid (Glycine) Conjugation

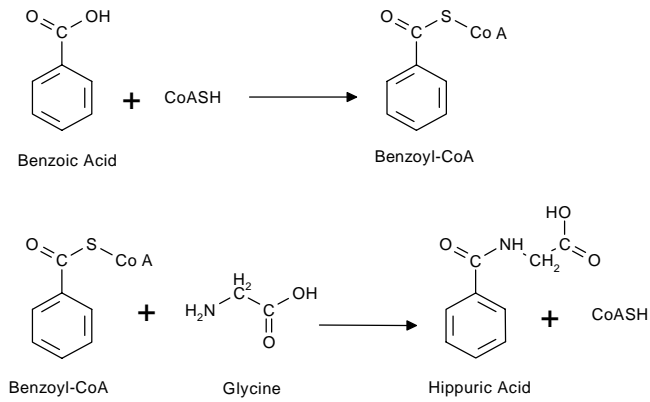

5) Mercapturic Acid Formation (Glutathione Conjugation)

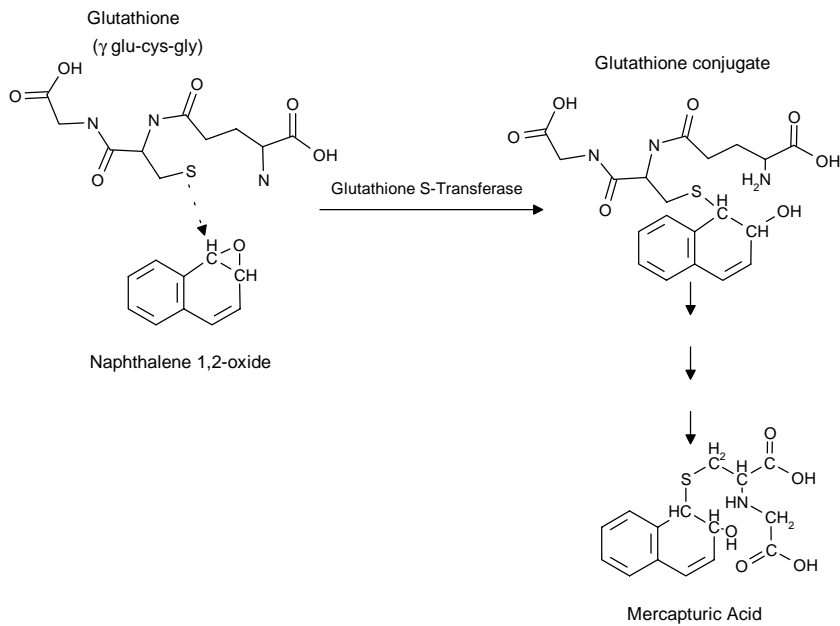

VII. Routes of Elimination

A. Renal Elimination

Three processes determine rate of clearance of drugs by the kidney:

- 1) Glomerular Filtration - **non-protein bound** drug molecules will be freely filtered
- 2) Tubular Reabsorption: Passive diffusion, which depends on Concentration, Molecular size, K_p, Degree of ionization
- 3) Tubular Secretion: Active process, primarily of anions (weak acids): Penicillins, Cephalosporins, Salicylates, Thiazides, "Loop" Diuretics, Sulfonamides, Uric acid, Lactic acid.

For drugs cleared by the kidney, a Clearance Ratio can be calculated, where

$$CR = \frac{Cl_{Drug}}{Cl_{Creatinine}}$$

Drugs that are **only filtered** will be cleared at a rate corresponding to the GFR, or the creatinine clearance rate (~120 ml min in a normal adult), and CR = 1.

Drugs that are **filtered and reabsorbed** will be cleared at a rate **lower** than the GFR, and CR < 1.

Drugs that are **filtered and actively secreted** will be cleared at a rate **greater** than the GFR, and CR > 1 (CR for penicillin is ~5).

B. Ion Trapping in the Urine: To enhance the elimination of weak bases (e.g., amines) acidify the urine with ammonium chloride. To enhance the elimination of weak acids, (e.g. aspirin) alkalinize the urine with sodium bicarbonate.

C. Ion Trapping in the Stomach (weak bases like morphine, cocaine)

D. Biliary Secretion and Enterohepatic Cycle

E. Exhalation of volatile compounds (basis of ethanol breath test)

F. Secretion of Drugs in Breast Milk

VIII. Pharmacokinetics

A. Zero Order Elimination: For drugs undergoing zero order elimination, a constant **AMOUNT** of drug is eliminated per unit time.

$$\frac{dC}{dt} = R$$

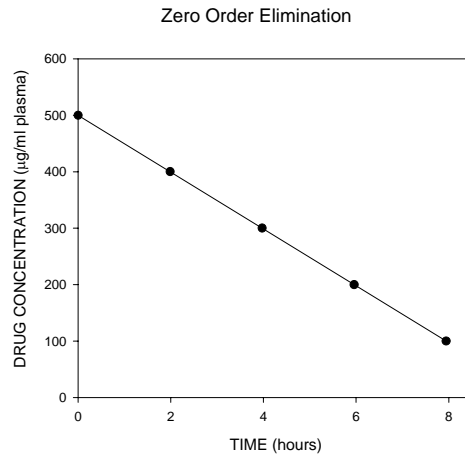

B. First Order Elimination: For drugs undergoing first order elimination, a constant **FRACTION** of the remaining amount of drug is eliminated per unit time.

$$\frac{dC}{dt} = K_E C$$

$$C_t = C_0 (e^{-K_E t})$$

Where C_0 = initial drug concentration; C_t = drug concentration at a given time, t ;
 K_E = the drug's elimination constant; and t = the time interval from time 0 to time t .

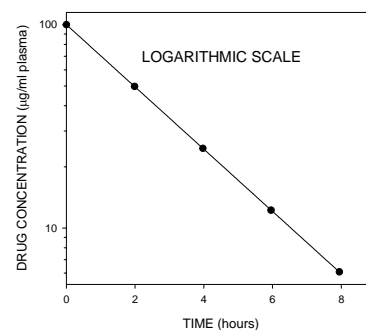
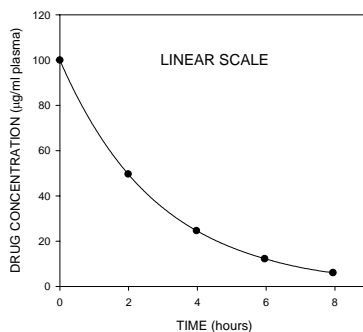

- C. Half-life:** The amount of time required to eliminate 50% of the drug in the body. The half-life can be determined from a semilog graph of the plasma concentration versus time or it can be calculated from the elimination constant.

$$T_{1/2} = \frac{0.693}{K_E}$$

- D. Elimination Constant:** The slope of a semilog plot of the plasma concentration versus time is equal to $-K_E/2.303$. However it is far easier to determine the half-life of the drug graphically, and calculate the elimination constant:

$$K_E = \frac{0.693}{T_{1/2}}$$

- E. Total Body Clearance:** The total body clearance of a drug may be calculated from the elimination constant and the apparent volume of distribution:

$$Cl_{Total} = (K_E)(V_d)$$

Drugs may be cleared from the plasma by several tissues including the kidney (renal clearance) and the liver (hepatic clearance). The total body clearance is equal to the sum of all the individual organ clearances:

$$Cl_{Total} = Cl_{Renal} + Cl_{Hepatic} + Cl_{Other}$$

Clearance is a fluid processing rate; it has units of fluid volume/unit time. That is because it depends on the efficiency with which the organs of metabolism or elimination (liver and kidney) can process the fluid (plasma) passing through them.

Another useful (but less intuitive) expression for total body clearance is given by the equation

$$Cl = \frac{(Dose)(F)}{AUC}$$

Where Cl is total body clearance, DOSE is the total amount of drug administered, F is the bioavailable fraction (see above), and AUC is the **total** area under the Disposition (plasma concentration vs. time) curve, from time 0 to infinity (or until the drug is gone).

AN EXAMPLE OF THE INFORMATION THAT CAN BE CALCULATED FROM A DRUG DISPOSITION CURVE

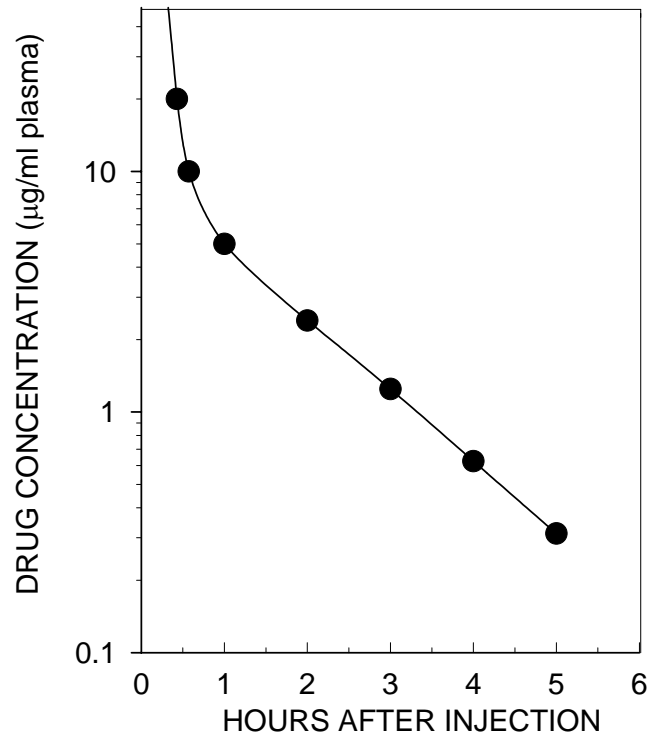

A single intravenous bolus of Drug X (100 mg) was administered to a 70 Kg man. The figure above shows the concentration of drug X in plasma as a function of time. Drug X does not bind to plasma proteins.

- A. What is the theoretical concentration of drug X in plasma at time zero?
- B. What is the apparent volume of distribution?
- C. What is the half-life of drug X in this man?
- D. What is the elimination constant for drug X?
- E. What is the total body clearance rate for drug X?

F. Drug Accumulation: When a drug is administered continuously or repeatedly, the drug will accumulate until the amount of drug eliminated per unit time is equal to the amount of drug administered in the same amount of time. At this point, the drug will achieve a **steady-state plasma concentration**.

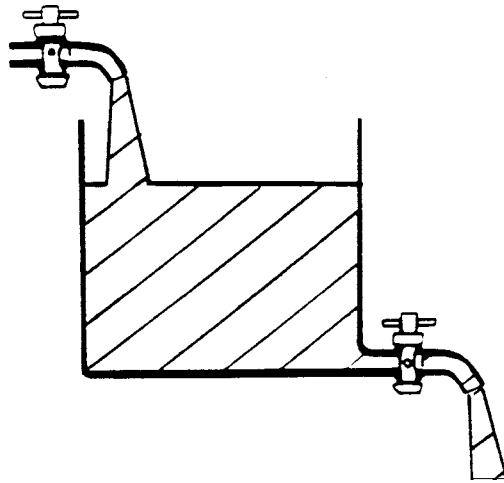

$$C_{SS} = \frac{Q}{Cl} = \frac{Q}{(K_E)(V_d)}$$

Where C_{SS} = steady state drug concentration; Q = infusion rate or dose per unit time; Cl = total body clearance; K_E = elimination constant; V_d = volume of distribution

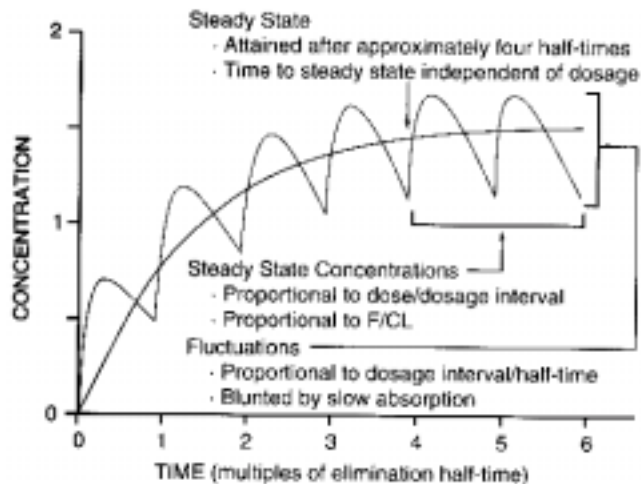
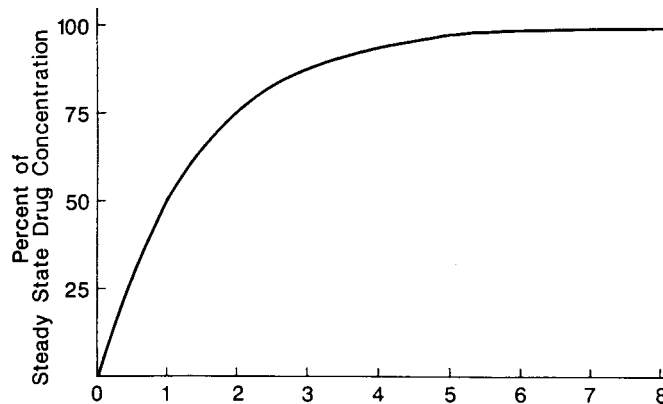

Figure 1-6. Fundamental pharmacokinetic relationships for repeated administration of drugs.

The amount of time it takes to achieve the steady-state concentration is dependent on the elimination constant only. The equation for drug accumulation in plasma is similar to the equation for drug elimination:

$$C_T = C_{SS}(1 - e^{-k_E T})$$

If a patient receives a constant infusion of a drug, the plasma drug concentration will be 50% ($1 - 1/2^1 = 1/2$) of the steady state concentration in one half-life, and 97% ($1 - 1/2^5 = 31/32$) of the steady state concentration in 5 half-lives.



In other words, the kinetics of accumulation is the mirror image of the kinetics of elimination:

Number of Half-lives	Infusion: Fraction Accumulated (C_T/C_{SS})	Elimination: Fraction Remaining (C_T/C_{SS})
1	0.50	0.50
2	0.75	0.25
3	0.88	0.12
4	0.94	0.06
5	0.97	0.03

The new steady-state concentration, C_{SS} , depends **on the ratio of Q and Cl**; the length of time it takes to reach the new C_{SS} depends **only on Cl, not on Q**.

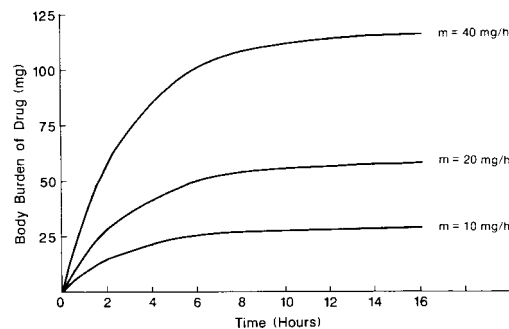

H. Dosing Regimens:

- # Loading Dose: Equals the amount of drug in the body at steady state

$$\text{Loading Dose} = (C_{SS})(V_d)$$

- # Maintenance Dose: Must equal the amount of drug lost per unit time.

$$\text{Dosing Rate} = Q = (Cl)(C_{SS})$$

For an oral dose, the dose per interval of time will have to be divided by F. More frequent oral dosing leads to less fluctuation in the peak and trough plasma concentrations. If the dose is administered at intervals equal to the half-life, the peak and trough values will vary by 50%.

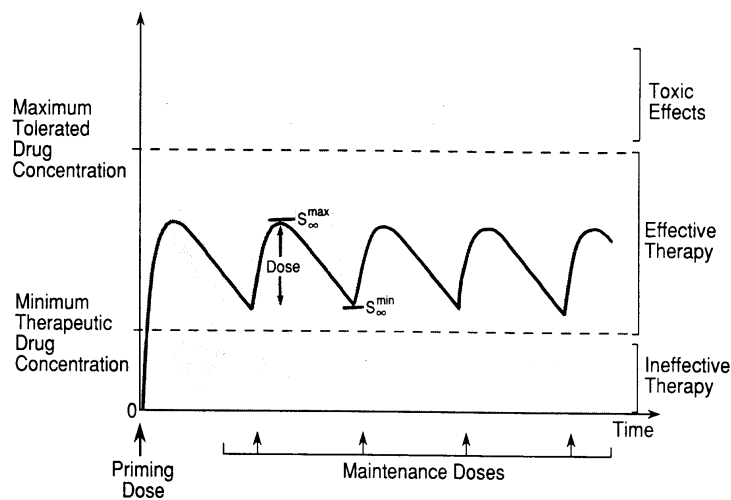

I. Individualizing Dosages in Renal or Hepatic Disease:

Hepatic disease may slow the metabolism of some drugs, and may decrease the hepatic clearance of the drug. Renal disease may slow the renal excretion of a drug and may decrease the drug's renal clearance. In the presence of such conditions, the loading dose required to produce a given plasma concentration remains the same. But *the maintenance dose must be adjusted for the decreased clearance rate*. Individualization of the maintenance dose to account for individual conditions of clearance (and bioavailability, in the case of oral doses) can be calculated by the equation:

$$\text{Individualized Dose} = \text{Average Dose} \frac{(Cl_{Indiv})(F_{Avg})}{(Cl_{Avg})(F_{Indiv})}$$

Where Cl_{indiv} is the clearance for the individual patient, Cl_{avg} is the "average" clearance, F_{avg} is the average bioavailable fraction, and F_{indiv} is the bioavailable fraction for the individual patient.