

**EFFICIENT UNCERTAINTY ANALYSIS METHODS FOR
MULTIDISCIPLINARY ROBUST DESIGN**

Xiaoping Du^{*} and Wei Chen⁺

University of Illinois at Chicago, Chicago, IL 60607, U.S.A.

Copyright © 2001 by Xiaoping Du and Wei Chen. Published by American Institute of aeronautics and Astronautics, Inc., with permission.

^{*} Research Assistant, Department of Mechanical Engineering. Member AIAA.

⁺ Associate Professor, Department of Mechanical Engineering, weichen1@uic.edu, (312)996-6072. Member AIAA

Abstract

Robust design has been gaining wide attention, and its applications have been extended to making reliable decisions when designing complex engineering systems in a multidisciplinary design environment. Though the usefulness of robust design is widely acknowledged for multidisciplinary design systems, its implementation is rare. One of the reasons is due to the complexity and computational burden associated with the evaluation of performance variations caused by the randomness (uncertainty) of a system. In this paper, a multidisciplinary robust design procedure that utilizes efficient methods for uncertainty analysis is developed. Different from the existing uncertainty analysis techniques, our proposed techniques bring the features of MDO framework into consideration. The system uncertainty analysis (SUA) method and the concurrent subsystem uncertainty analysis (CSSUA) method are developed to estimate the mean and variance of system performance subject to uncertainties associated with both design parameters and design models. As shown both analytically and empirically, compared to the conventional Monte Carlo simulation approach, the proposed techniques used for uncertainty analysis will significantly reduce the amount of design evaluations at the system level, and therefore improve the efficiency of robust design in the domain of MDO. A mathematical example and an electronic packaging problem are used as examples to verify the effectiveness of these approaches.

1. Introduction

Robust design has been gaining wide attention and its applications have been extended from improving the quality of individual components to designing complex engineering systems. The methods for robust design have progressed from the initial Taguchi's "parameter design method"¹ to recent nonlinear programming methods^{2 - 4} that formulate robust design problems as nonlinear optimization problems with multiple objectives subject to feasibility robustness^{5, 6}. Based on its fundamental principle, i.e., improving the quality of a product by minimizing the effects of variation without eliminating the causes¹, robust design has become one of the powerful tools to assist designers to make reliable decisions under uncertainty⁷. In designing complex engineering systems, Multidisciplinary Design Optimization (MDO)⁸⁻¹⁰ has become a systematic approach to optimization of complex, coupled engineering systems, where "multidisciplinary" refers to the different aspects that must be included in designing a system that involves multiple interacting disciplines, such as those found in aircraft, spacecraft, automobiles, and industrial manufacturing applications. It is generally recognized that there always exist uncertainties in any engineering system due to variations in design conditions and predictions used in mathematical models⁷. However, even though we have seen many applications of MDO, the treatment of uncertainties under multidisciplinary design has received very limited attention^{11, 12}. There is a great potential to integrate the robust design concept and the MDO framework for rational decision-making in designing complex systems.

In recent developments, some preliminary results of robust design for MDO are reported^{11 - 14}. In these works, response surface models for system level objective and constraints are created to replace the computationally expensive simulation models. Based on the simplified

models, the mean and variance of the system behaviors are evaluated through uncertainty analysis (propagating the effect of uncertainty) and then utilized to obtain the robust optimal solutions. When conducting uncertainty analysis, most of these approaches utilize design evaluations at the system level, namely, the all-in-one approach. The drawback of using the response surface modeling approach is the cost associated with generating an accurate response surface model over a large parameter space (for both deterministic and random variables). Besides, some of the response surface methods tend to “smooth” the behavior. This results in large errors when the smooth function is used to evaluate local sensitivities in uncertainty analysis.

In developing efficient methods for uncertainty analysis, many researches have been focused on design problems with a single discipline or an all-in-one integrated analysis. Existing methods include Monte Carlo simulation¹⁵, first-order second-moment analysis^{5, 16}, stochastic response surface methods¹⁷, polynomial chaos expansion method¹⁸, and reliability analysis based approaches¹⁹. Most of these applications are limited to modeling the uncertainty of input parameters. In recent developments, some preliminary results of propagating model (structure) uncertainty are reported. Du and Chen⁷ applied the extreme condition approach and the statistical approach to propagating the effect of both parameter and model uncertainties. The extreme condition approach is to derive the range of a system output in terms of the range of uncertainties by sub-optimizations (minimization and maximization of the performance). The statistical approach relies heavily on the use of data sampling to generate probabilistic distributions of system output. Very few works exist on propagating the effect of uncertainty in the context of multidisciplinary design. Preliminary results were published recently by Gu et al.²⁰ on this topic. With their approach, model

uncertainty is denoted by a range (bias) of the system output; the “worst case” concept and the first-order sensitivity analysis are used to evaluate the interval of the end performance of a multidisciplinary system. Methods that could accommodate generic probabilistic representations of uncertain parameters and model error estimations have not yet been fully developed.

Our aim in this paper is to facilitate the integration of the robust design concept with MDO by developing efficient methods for uncertainty analysis that bring the features of MDO framework into consideration. To improve the computational efficiency in the context of highly coupled analyses, two techniques, namely, the system uncertainty analysis (SUA) method and the concurrent subsystem uncertainty analysis (CSSUA) method, are developed. The former approach utilizes Taylor expansion as well as local and global sensitivity analysis (first-order derivatives) to evaluate the mean and variance of a system output, while the later uses only local sensitivities and a parallel scheme that allows uncertainty analysis implemented concurrently at the subsystem level. The developed methods will assist designers to make reliable decisions when there are uncertainties associated with both design parameters and design models. Both methods will significantly reduce the amount of design evaluations at the system level, and therefore improve the efficiency of robust design in the domain of MDO.

Our paper is organized as follows. In Section 2, the need for considering various sources of uncertainties in simulation-based multidisciplinary system design is addressed along with the uncertainty representation in a multidisciplinary system. Our proposed methods for uncertainty analysis and the integration of these methods with MDO are presented in Section 3. In Section 4, Two examples are used to illustrate the effectiveness of our methods. Section

5 is the closure which highlights the effectiveness of the proposed methods and provides discussions on their applicability under different circumstances.

2. Uncertainty Modeling in Simulation-Based Multidisciplinary Design

2.1 Sources of Uncertainties

In simulation-based design, the model-predicted performance and the actual system performance often deviate at certain levels. Under a multidisciplinary design environment, a system is composed of multidisciplinary subsystems each using a variety of disciplinary models with uncertainties associated with performance predications. These subsystems are often highly coupled where the performance prediction of one discipline may become the input of another discipline and vice versa^{8, 21}. A critical issue in simulation-based multidisciplinary design is that the uncertainties of one discipline may be propagated to another discipline through the linking variables and the final output from the integrated multidisciplinary system has an accumulation of the uncertainties from the individual disciplines. This feature has posed additional challenges in developing efficient uncertainty analysis techniques for multidisciplinary systems.

Omitting the algorithmic errors related to computer implementations, several general sources contribute to the uncertainties in simulation predictions:

- Variability of input values x (including both design parameters and design variables), called “*input parameter uncertainty*”⁷;
- Uncertainty due to limited information in estimating the characteristics of model parameters p , which are parameter components of a model, e. g. the physical constant of a model, called “*model parameter uncertainty*”^{22, 23};

- Uncertainty in the model structure itself (including uncertainty in the validity of the assumptions underlying the model), referred to as “*model structure uncertainty*”^{24, 25}.

We refer to “input parameter uncertainty” and “model parameter uncertainty” together as “*parameter uncertainty*”, and “model structure uncertainty” as “*model uncertainty*”. Quantification of model uncertainty is more complicated compared to that of the parameter uncertainty. It is still an ongoing research issue in both academia and industry^{24, 25}. We use the probabilistic notion to suggest that all types of uncertainties studied in this work will be measured by probability distributions of simulation predictions. One method to consider the model uncertainty is to introduce a function $\boldsymbol{\varepsilon}(\mathbf{x})$ of simulation input into the simulation output function $F(\mathbf{x})$ as

$$\mathbf{z} = \mathbf{F}(\mathbf{x}) + \boldsymbol{\varepsilon}(\mathbf{x}). \quad (1)$$

Generally, $\boldsymbol{\varepsilon}(\mathbf{x})$ is a random function even under the condition that \mathbf{x} is deterministic.

2.2 Description of Multidisciplinary System under Uncertainties

Fig.1 shows the n-discipline system, where each box represents a simulation program that belongs to a discipline (or subsystem) for design evaluation. \mathbf{x}_s are the input variables considered by more than one subsystem, also called sharing variables. \mathbf{x}_i ($i = 1, n$) are the input variables of subsystem i . Note that \mathbf{x}_s and \mathbf{x}_i are mutually exclusive sets of input variables. Uncertainties may be associated with \mathbf{x}_s and \mathbf{x}_i which can be expressed by probabilistic distributions.

\mathbf{y}_{ij} ($i \neq j$) are linking variables, which are those functional outputs calculated in subsystem i , at the same time, are required as inputs to subsystem j . For simplification of representation, we denote $\mathbf{y}_i = \{\mathbf{y}_{ij} | j = 1, n, j \neq i\}$ as the set of linking variables generated as

outputs from subsystem i and taken as inputs to the other subsystems, and $\mathbf{y}^i = \{\mathbf{y}_1, \dots, \mathbf{y}_{i-1}, \mathbf{y}_{i+1}, \dots, \mathbf{y}_n\}$ as the set of linking variables generated as outputs from each of the subsystem except subsystem i and taken as inputs to subsystem i .

For subsystem i , based on the subsystem simulation model $\mathbf{F}_{yi}(\cdot)$ and the corresponding model error $\boldsymbol{\varepsilon}_{yi}(\cdot)$, the linking variables can be derived as:

$$\mathbf{y}_i = \mathbf{F}_{yi}(\mathbf{x}_s, \mathbf{x}_i, \mathbf{y}^i) + \boldsymbol{\varepsilon}_{yi}(\mathbf{x}_s, \mathbf{x}_i, \mathbf{y}^i). \quad (2)$$

Similarly, the general output of subsystem i , $\mathbf{z}_i (i = 1, n)$, can be derived as:

$$\mathbf{z}_i = \mathbf{F}_{zi}(\mathbf{x}_s, \mathbf{x}_i, \mathbf{y}^i) + \boldsymbol{\varepsilon}_{zi}(\mathbf{x}_s, \mathbf{x}_i, \mathbf{y}^i). \quad (3)$$

The outputs of each subsystem \mathbf{z}_i , which may include linking variables, are often associated with the system attributes for the evaluations of constraints and objectives in optimization. In the situation that an objective (or constraint) is a function of several system attributes coming from the analyses of different disciplines, a separate subsystem evaluation can be formed for this purpose.

In propagating the effect of uncertainty, the goal is to quantify the distributions of system outputs \mathbf{z}_i for the given parameter uncertainty and the model uncertainty. If we choose to use the first and second moments (mean value and variance) to describe the distributions, such as the situation in robust design the problem is stated as:

Given: mean values and variances of input variables

$$\boldsymbol{\mu}_{xs}, \boldsymbol{\mu}_{xi}, \boldsymbol{\sigma}_{xs}, \text{ and } \boldsymbol{\sigma}_{xi} \quad (i = 1, n)$$

mean values and variances of model errors

$$\boldsymbol{\mu}_{yi}, \boldsymbol{\mu}_{zi}, \boldsymbol{\sigma}_{yi} \text{ and } \boldsymbol{\sigma}_{zi} \quad (i = 1, n)$$

Find: mean values and variances of system outputs

$$\boldsymbol{\mu}_{zi} \text{ and } \boldsymbol{\sigma}_{zi} \quad (i = 1, n)$$

3. Techniques for Uncertainty Analysis in Multidisciplinary Robust Design

Both the system uncertainty analysis (SUA) method and the concurrent subsystem uncertainty analysis (CSSUA) method are developed to derive the mean and the variance of a system attribute in a multidisciplinary system. The former approach utilizes Taylor approximations as well as local and global sensitivity analysis (first-order derivatives), while the later uses only local sensitivities and a parallel scheme that allows uncertainty analysis implemented concurrently at the subsystem level. In a distributed design environment, a parallel scheme is often desired to decouple the multidisciplinary analysis so that individual groups can work independently from others.

3.1 The SUA method

1) Evaluate mean values

With the SUA method, the mean values of linking variables and system outputs are approximated at the mean values of inputs as

$$\boldsymbol{\mu}_{yi} = \mathbf{F}_{yi}(\boldsymbol{\mu}_{xs}, \boldsymbol{\mu}_{xi}, \boldsymbol{\mu}_y^i) + \boldsymbol{\mu}_{\varepsilon yi}, \quad (4)$$

and

$$\boldsymbol{\mu}_{zi} = \mathbf{F}_{zi}(\boldsymbol{\mu}_{xs}, \boldsymbol{\mu}_{xi}, \boldsymbol{\mu}_y^i) + \boldsymbol{\mu}_{\varepsilon zi}. \quad (5)$$

The evaluations of Eqs. (4) and (5) require analyses at the system level.

2) Derive system variance

To obtain the variances of system outputs, firstly, linking variables y_i ($i = 1, n$) are linearized by the first-order Taylor approximations expanded at the mean values identified previously in Eq. (4) through system-level evaluations. Multiple linking variables are derived simultaneously based on a set of linear equations. Secondly, we approximate a system output by the first-order Taylor expansion with respect to input variables \mathbf{x}_s , \mathbf{x}_i and linking

variables \mathbf{y}_i in each subsystem. After substituting \mathbf{y}_i with the approximation derived earlier, we have the approximation of a system output as the function of input variables \mathbf{x}_s , \mathbf{x}_i only. Finally, based on the approximated system output, its variance is evaluated. The detailed procedure is as follows.

From Eq. (2), the linking variables \mathbf{y}_i are approximated using Taylor's expansion as

$$\Delta \mathbf{y}_i = \sum_{\substack{j=1 \\ j \neq i}}^n \frac{\partial \mathbf{F}_{yi}}{\partial \mathbf{y}_j} \Delta \mathbf{y}_j + \frac{\partial \mathbf{F}_{yi}}{\partial \mathbf{x}_s} \Delta \mathbf{x}_s + \frac{\partial \mathbf{F}_{yi}}{\partial \mathbf{x}_i} \Delta \mathbf{x}_i + \Delta \boldsymbol{\varepsilon}_{yi}, \quad (i=1, n) \quad (6)$$

which can be written in a matrix form

$$\mathbf{A} \Delta \mathbf{y} = \mathbf{B} \Delta \mathbf{x}_s + \mathbf{C} \Delta \mathbf{x} + \mathbf{D}, \quad (7)$$

where

$$\mathbf{A} = \begin{bmatrix} \mathbf{I}_1 & -\frac{\partial \mathbf{F}_{y1}}{\partial \mathbf{y}_2} & \dots & -\frac{\partial \mathbf{F}_{y1}}{\partial \mathbf{y}_n} \\ -\frac{\partial \mathbf{F}_{y2}}{\partial \mathbf{y}_1} & \mathbf{I}_2 & \dots & -\frac{\partial \mathbf{F}_{y2}}{\partial \mathbf{y}_n} \\ \dots & \dots & \dots & \dots \\ -\frac{\partial \mathbf{F}_{yn}}{\partial \mathbf{y}_1} & -\frac{\partial \mathbf{F}_{yn}}{\partial \mathbf{y}_2} & \dots & \mathbf{I}_n \end{bmatrix}, \quad \mathbf{B} = \begin{bmatrix} \frac{\partial \mathbf{F}_{y1}}{\partial \mathbf{x}_s} \\ \frac{\partial \mathbf{F}_{y2}}{\partial \mathbf{x}_s} \\ \dots \\ \frac{\partial \mathbf{F}_{yn}}{\partial \mathbf{x}_s} \end{bmatrix}, \quad \mathbf{C} = \begin{bmatrix} \frac{\partial \mathbf{F}_{y1}}{\partial \mathbf{x}_1} & 0 & \dots & 0 \\ 0 & \frac{\partial \mathbf{F}_{y2}}{\partial \mathbf{x}_2} & \dots & 0 \\ \dots & \dots & \dots & \dots \\ 0 & 0 & \dots & \frac{\partial \mathbf{F}_{yn}}{\partial \mathbf{x}_n} \end{bmatrix},$$

$$\mathbf{D} = \begin{bmatrix} \boldsymbol{\varepsilon}_{y1} - \boldsymbol{\mu}_{\varepsilon y1} \\ \boldsymbol{\varepsilon}_{y2} - \boldsymbol{\mu}_{\varepsilon y2} \\ \dots \\ \boldsymbol{\varepsilon}_{yn} - \boldsymbol{\mu}_{\varepsilon yn} \end{bmatrix}, \quad \Delta \mathbf{x}_s = \mathbf{x}_s - \boldsymbol{\mu}_{x_s}, \quad \Delta \mathbf{x} = \begin{bmatrix} \mathbf{x}_1 - \boldsymbol{\mu}_{x1} \\ \mathbf{x}_2 - \boldsymbol{\mu}_{x2} \\ \dots \\ \mathbf{x}_n - \boldsymbol{\mu}_{xn} \end{bmatrix}, \quad \text{and} \quad \Delta \mathbf{y} = \begin{bmatrix} \mathbf{y}_1 - \boldsymbol{\mu}_{y1} \\ \mathbf{y}_2 - \boldsymbol{\mu}_{y2} \\ \dots \\ \mathbf{y}_n - \boldsymbol{\mu}_{yn} \end{bmatrix}.$$

\mathbf{I}_i ($i = 1, n$) are the identity matrixes.

Solving a system of equations in Eq. (7) yields

$$\Delta \mathbf{y} = \mathbf{A}^{-1} \mathbf{B} \Delta \mathbf{x}_s + \mathbf{A}^{-1} \mathbf{C} \Delta \mathbf{x} + \mathbf{A}^{-1} \mathbf{D}. \quad (8)$$

Similarly, system outputs are approximated as

$$\Delta z_i = \sum_{\substack{j=1 \\ j \neq i}}^n \frac{\partial F_{zi}}{\partial y_j} \Delta y_j + \frac{\partial F_{zi}}{\partial x_s} \Delta x_s + \frac{\partial F_{zi}}{\partial x_i} \Delta x_i + \Delta \varepsilon_{zi}, \quad (i=1, n), \quad (9)$$

which can be expressed by the matrix form

$$\Delta \mathbf{z} = \mathbf{E} \Delta \mathbf{y} + \mathbf{F} \Delta \mathbf{x}_s + \mathbf{G} \Delta \mathbf{x} + \mathbf{H} = [\mathbf{E}(\mathbf{A}^{-1}\mathbf{B}) + \mathbf{F}] \Delta \mathbf{x}_s + [\mathbf{E}(\mathbf{A}^{-1}\mathbf{C}) + \mathbf{G}] \Delta \mathbf{x} + \mathbf{E} \mathbf{A}^{-1} \mathbf{D} + \mathbf{H}, \quad (10)$$

$$\text{where } \mathbf{E} = \begin{bmatrix} 0 & \frac{\partial F_{z1}}{\partial y_2} & \dots & \frac{\partial F_{z1}}{\partial y_n} \\ \frac{\partial F_{z2}}{\partial y_1} & 0 & \dots & \frac{\partial F_{z2}}{\partial y_n} \\ \dots & \dots & \dots & \dots \\ \frac{\partial F_{zn}}{\partial y_1} & \frac{\partial F_{zn}}{\partial y_2} & \dots & 0 \end{bmatrix}, \quad \mathbf{F} = \begin{bmatrix} \frac{\partial F_{z1}}{\partial x_s} \\ \frac{\partial F_{z2}}{\partial x_s} \\ \dots \\ \frac{\partial F_{zn}}{\partial x_s} \end{bmatrix},$$

$$\mathbf{G} = \begin{bmatrix} \frac{\partial F_{z1}}{\partial x_1} & 0 & \dots & 0 \\ 0 & \frac{\partial F_{z2}}{\partial x_2} & \dots & 0 \\ \dots & \dots & \dots & \dots \\ 0 & 0 & \dots & \frac{\partial F_{zn}}{\partial x_n} \end{bmatrix}, \quad \Delta \mathbf{z} = \begin{bmatrix} z_1 - \mu_{z1} \\ z_2 - \mu_{z2} \\ \dots \\ z_n - \mu_{zn} \end{bmatrix}, \quad \text{and } \mathbf{H} = \begin{bmatrix} \varepsilon_{z1} - \mu_{\varepsilon1} \\ \varepsilon_{z2} - \mu_{\varepsilon2} \\ \dots \\ \varepsilon_{zn} - \mu_{\varepsilon n} \end{bmatrix}.$$

Since in Eq. (10), $\Delta \mathbf{x}_s$, $\Delta \mathbf{x}$, \mathbf{D} and \mathbf{H} are mutually independent, the variance of the system output can be expressed as

$$\mathbf{D}_z = \mathbf{I} \mathbf{D}_{xs} + \mathbf{J} \mathbf{D}_x + \mathbf{K} \mathbf{D}_{y\varepsilon} + \mathbf{D}_{z\varepsilon}, \quad (11)$$

$$\text{where } \mathbf{D}_z = \begin{bmatrix} \sigma_{z1}^2 \\ \sigma_{z2}^2 \\ \dots \\ \sigma_{zn}^2 \end{bmatrix}, \quad \mathbf{D}_y = \begin{bmatrix} \sigma_{y1}^2 \\ \sigma_{y2}^2 \\ \dots \\ \sigma_{yn}^2 \end{bmatrix}, \quad \mathbf{D}_x = \sigma_x^2, \quad \mathbf{D}_{xs} = \begin{bmatrix} \sigma_{x1}^2 \\ \sigma_{x2}^2 \\ \dots \\ \sigma_{xn}^2 \end{bmatrix}, \quad \mathbf{D}_{y\varepsilon} = \begin{bmatrix} \sigma_{y\varepsilon1}^2 \\ \sigma_{y\varepsilon2}^2 \\ \dots \\ \sigma_{y\varepsilon n}^2 \end{bmatrix}, \quad \mathbf{D}_{z\varepsilon} = \begin{bmatrix} \sigma_{z\varepsilon1}^2 \\ \sigma_{z\varepsilon2}^2 \\ \dots \\ \sigma_{z\varepsilon n}^2 \end{bmatrix},$$

$$\mathbf{I} = \{i_{ij}\}, \quad i_{ij} = \{\mathbf{E}(\mathbf{A}^{-1}\mathbf{B}) + \mathbf{F}\}_{ij}^2, \quad \mathbf{J} = \{j_{ij}\}, \quad j_{ij} = \{\mathbf{E}(\mathbf{A}^{-1}\mathbf{C}) + \mathbf{G}\}_{ij}^2, \quad \mathbf{K} = \{k_{ij}\},$$

$k_{ij} = \{\mathbf{E} \mathbf{A}^{-1}\}_{ij}^2$, and all the σ^2 are the variance vectors.

All \mathbf{D} s in Eq. (11) stand for vectors of variance and \mathbf{I} , \mathbf{J} , \mathbf{K} are matrices of derivatives of linking variables and system outputs with respect to input variables. From this equation, it is noted that the total variation of a system output is derived as the sum of the variations contributed by four individual sources, i.e., the uncertainties of the sharing variables \mathbf{x}_s , the variation of subsystem input variables \mathbf{x}_i , the variation of linking variable \mathbf{y}_i due to model uncertainty, and the variation of system output \mathbf{z}_i due to model uncertainty.

3.2 The CSSUA method

In the SUA method, for the evaluation of the mean value of a system output, one analysis at the system level is required. To avoid any system level analysis in the case that it is very expensive, we developed the concurrent subsystem uncertainty analysis (CSSUA) method. The basic idea of the CSSUA method is to facilitate the parallelization of the variance evaluation for system outputs that are contributed by different subsystems. This is accomplished by making use of optimization technique to find the means of system output where only subsystem analyses are involved. Once the means of the system output are obtained, we use the same procedure as we developed for the SUA method to evaluate the variances of system output. The procedure is as follows.

1) Find mean values of linking variable by the suboptimization as shown in Fig. 2.

Here, the compatibility of the system is achieved by an optimizer which sets the target values of the mean values of linking variables and minimizes the deviations between the targets and those that are actually generated through the subsystems analyses. The idea can be generated as the following unconstrained optimization model:

Given: mean values of input variables

$$\boldsymbol{\mu}_{xs} \text{ and } \boldsymbol{\mu}_{xi} \text{ (} i = 1, n \text{)}$$

Find: target mean values of linking variable

$$\mu_{yi}^* \quad (i = 1, n)$$

$$\text{Minimize: } d = \min \sum_{i=1}^n (\mu_{yi} - \mu_{yi}^*)^2$$

μ_{yi}^* are the unknown variables in the suboptimization and μ_{yi} are the mean values of linking variables evaluated in subsystems. μ_{yi} are evaluated by Eq. (4).

2) Evaluate the mean value of a system output

The mean value of a system output is evaluated by substituting the mean of linking variable μ_{yi} in Eq. (5) with the suboptimization result.

3) Evaluate variance of a system output

Following the same procedure from Eqs. (6) through (11) as previously shown in the SUA method, we obtain the system output variance in the same expression as Eq. (11).

In the CSSUA, all analyses are implemented within subsystems and they can be parallelized easily. From the preceding procedure, it is noted that if the suboptimization generates the same mean values of linking variables as those obtained by the simultaneous evaluations of linking variables in the SUA method, the result of uncertainty analysis of the SUA and the CSSUA are identical.

3.3 Efficiency of SUA and CSSUA

As it will be demonstrated in the example problems, our proposed techniques are much more efficient than the conventional Monte Carlo Simulations. To choose between the SUA and the CSSUA methods, we need to consider the number of all-in-one system level analysis and the number of subsystem level analysis, as well as the time needed for each of these analyses, for each different problems. To provide good guidelines for choosing the most appropriate technique, we derive analytically the numbers of system and subsystem analyses

needed for the SUA and the CSSUA methods, respectively, as functions of the number of input linking variables, the number of subsystem output, the number of sharing variables, the number of subsystem input variables, and the number of output linking variables.

For each uncertainty analysis, the SUA method needs one system level analysis while the CSSUA does not require any system level analysis. On the other hand, the CSSUA method requires more subsystem level analyses (subsystem analyses) than the SUA due to the suboptimization involved in uncertainty analysis. Assuming that the derivatives needed for uncertainty analysis (Eqs. 7 and 10) are evaluated numerically, the number of subsystem analysis for each different method is derived as the following.

1) The number of subsystem analysis for SUA

$$N_{SUA} = \sum_{i=1}^n [N_{y_output}(i) + N_z(i)] \times [1 + N_{xs} + N_x(i) + N_{y_input}(i)], \quad (12)$$

where $N_{y_output}(i)$ - number of output linking variable y_i (as the output of subsystem i),

$N_z(i)$ - number of system output of subsystem i ,

N_{xs} - number of sharing input variables,

$N_x(i)$ - number of input variables for subsystem i ,

$N_{y_input}(i)$ - number of input linking variables y^i (as the input for subsystem i).

n – the number of disciplines

The item in the first square brackets is the number of the output of s subsystem and the item in the second square brackets is the number of the output of a subsystem plus one. The total number of subsystem analyses is the summation of the number of subsystem analyses of each subsystem.

2) The number of subsystem analysis for the CSSUA

$$N_{CSSUA} = N_{fun_call} \sum_{i=1}^n N_{y_output}(i) + \sum_{i=1}^n [N_{y_output}(i) + N_z(i)] \times [1 + N_{xs} + N_x(i) + N_{y_input}(i)] \quad (13)$$

where N_{fun_call} is the number of function evaluations for suboptimization.

The first part on the right hand side in Eq. 13 is the number of subsystem analyses for suboptimization and the second part is the number of subsystem analyses for the variance evaluations after the suboptimization.

By subtracting Eq. 12 from Eq. 13, we have

$$N_{CSSUA} = nN_{fun_call} + N_{SUA}. \quad (14)$$

The difference of numbers of subsystem analyses of the SUA and the CSSUA becomes the sum of the number of function evaluations (in suboptimization) multiplies the number of subsystems, i.e., nN_{fun_call} . If we can estimate the computational effort for one all-in-one system analysis as the equivalent number of that for subsystem analyses, then we may prefer the SUA to CSSUA in the case that the equivalent number of subsystem analyses for the SUA is less than nN_{fun_call} , otherwise we would liked to choose the CSSUA.

It should be noted that in the case that parallization (distributed analysis) is considered for subsystem analysis under the CSSUA, the total amount of time needed (considering the parallization scheme) will be a better measure than the total number of subsystem analysis when choosing which method to use.

The proposed methods are developed for MDO implementation considering the features of a MDO framework. They are in general more efficient than the conventional Monte Carlo simulation (MCS) approach. To evaluate the means and the standard deviations of system outputs and linking variables, the MCS will need hundreds of simulations to obtain accurate estimations, and these simulations need to be conducted at the all-in-one system level. For

closed loop systems, this means for each Monte Carlo simulation, multiple subsystem analysis from each discipline will be needed to reach convergence. The multiplication will often result in much larger number of subsystem analysis for MCS than for the SUA and CSSUA methods. In the case that the derivatives needed for uncertainty analysis can be derived analytically instead of numerically, the advantages of using our proposed methods will be even more superior than using MCS. In that the case, for each uncertainty analysis, the computational effort of the proposed methods is similar to the computational effort of only one simulation of the MCS. In the case that those derivatives need to be evaluated numerically, the advantages of the SUA and CSSUA methods may diminish when the system has a very large number of random variables, for example, thousands random variables. In that case, the MCS approach will be more favorable.

3.4 Formulation of Multidisciplinary Robust Optimization

From the viewpoint of robust design, the goal of a design is to make the system (or product) inert to the potential variations without eliminating the sources of uncertainty¹⁵. The same concept is used here to reduce the impact of both parameter and model uncertainties associated with MDO. The robust optimization objective is achieved by simultaneously “optimizing the mean performance” and “reducing the performance variation”, subject to the robustness of constraints⁵. Let $\mathbf{a}(\mathbf{x}_s, \mathbf{x})$ and $\mathbf{g}(\mathbf{x}_s, \mathbf{x})$ be the objective and constraints of a system, respectively, the general form of the objective can be expressed as

$$\min [\boldsymbol{\mu}_a(\mathbf{x}_s, \mathbf{x}), \boldsymbol{\sigma}_a(\mathbf{x}_s, \mathbf{x})], \quad (15)$$

where $\boldsymbol{\mu}_a(\mathbf{x}_s, \mathbf{x})$ and $\boldsymbol{\sigma}_a(\mathbf{x}_s, \mathbf{x})$ are the mean value and the standard deviation of $\mathbf{a}(\mathbf{x}_s, \mathbf{x})$, respectively and $\mathbf{x}=\{\mathbf{x}_1, \mathbf{x}_2, \dots, \mathbf{x}_n\}$. Feasibility robustness can be achieved by increasing the values of constraint functions by the amount of functional variations¹⁰ as

$$\boldsymbol{\mu}_g + k\boldsymbol{\sigma}_g \leq 0, \quad (16)$$

where $\boldsymbol{\mu}_g$ and $\boldsymbol{\sigma}_g$ are the mean values and the standard deviations of $\mathbf{g}(\mathbf{x}_s, \mathbf{x})$. k is a constant related to the probability of constraint satisfaction. For example, when $\mathbf{g}(\mathbf{x}_s, \mathbf{x})$ follows the normal distribution, $k=1$ corresponds to the probability ≈ 0.8413 , $k=2$ the probability ≈ 0.9772 , etc. The robust design model is summarized as:

- Given:** Mean and variance of parameter and model uncertainties
Find: robust design decisions (\mathbf{x}_s and \mathbf{x})
Subject to: system constraints:
 $\boldsymbol{\mu}_g + k\boldsymbol{\sigma}_g \leq 0$
Objectives: optimize the mean of system attributes $\boldsymbol{\mu}_a(\mathbf{x}_s, \mathbf{x})$
minimize the standard deviation of system attributes $\boldsymbol{\sigma}_a(\mathbf{x}_s, \mathbf{x})$

The mean values $\boldsymbol{\mu}_a$ and $\boldsymbol{\mu}_g$, and the standard deviations $\boldsymbol{\sigma}_a$ and $\boldsymbol{\sigma}_g$ can be obtained by either the SUA or the CSSUA method. It is noted that if the CSSUA is used, the suboptimization should be performed under the robust optimization and the whole robust design will be a double loop procedure. Multiobjective techniques for making tradeoffs between the mean and variance aspects in robust design have been fully investigated in our earlier study²⁶.

The total number of subsystem analyses is approximated equal to the number of function evaluation of the optimization for robust design times the numbers listed in Eqs. (12) and (13) for the SUA and the CSSUA respectively. The total number of system analyses for the SUA is equal to the number of function evaluation of the optimization for robust design.

4. Examples

Two examples are used to illustrate the effectiveness of our proposed uncertainty analysis techniques. The accuracy of using the SUA and the CSSUA methods for both

multidisciplinary design evaluations (analyses) and optimization is examined. To verify the results, Monte Carlo Simulations (MCS) are also used for both uncertainty analysis and robust design. A large simulation size, 10^6 , is adopted for each uncertainty analysis and the result from the MCS is considered as the correct solution for the purpose of confirmation. The modified feasible direction method is used as the optimizer for both suboptimization for uncertainty analysis and system optimization for robust design.

4.1 A Mathematical Example

Problem statement

Two subsystems are considered in this example. The functional relationships are represented as:

Subsystem 1

$$\mathbf{x}_s = \{x_1\}, \mathbf{x}_1 = \{x_2, x_3\}, \mathbf{y}_1 = \mathbf{y}_{12} = \{y_{12}\}, \mathbf{z}_1 = \{z_1\}, \quad (17a)$$

$$\boldsymbol{\varepsilon}_{y_1}(\mathbf{x}_s, \mathbf{x}_1, \mathbf{y}_1) = \{\varepsilon_{y_{12}}(\mathbf{x}_s, \mathbf{x}_1, \mathbf{y}_1)\}, \boldsymbol{\varepsilon}_{z_1}(\mathbf{x}_s, \mathbf{x}_1, \mathbf{y}_1) = \{\varepsilon_{z_1}(\mathbf{x}_s, \mathbf{x}_1, \mathbf{y}_1)\}, \quad (17b)$$

$$\mathbf{F}_{y_{12}}(\mathbf{x}_s, \mathbf{x}_1, \mathbf{y}_1) = \{F_{y_{12}}(\mathbf{x}_s, \mathbf{x}_1, \mathbf{y}_1)\} = x_1^2 + 2x_2 - x_3 + 2\sqrt{y_{12}} \quad (17c)$$

$$\mathbf{F}_{z_1}(\mathbf{x}_s, \mathbf{x}_1, \mathbf{y}_1) = \{F_{z_1}(\mathbf{x}_s, \mathbf{x}_1, \mathbf{y}_1)\} = x_1^2 + 2x_2 + x_3 + x_2 e^{-y_{12}} \quad (17d)$$

Subsystem 2

$$\mathbf{x}_s = \{x_1\}, \mathbf{x}_2 = \{x_4, x_5\}, \mathbf{y}_2 = \mathbf{y}_{21} = \{y_{21}\}, \mathbf{z}_2 = \{z_2\}, \quad (18a)$$

$$\boldsymbol{\varepsilon}_{y_2}(\mathbf{x}_s, \mathbf{x}_2, \mathbf{y}_2) = \{\varepsilon_{y_{21}}(\mathbf{x}_s, \mathbf{x}_2, \mathbf{y}_2)\}, \boldsymbol{\varepsilon}_{z_2}(\mathbf{x}_s, \mathbf{x}_2, \mathbf{y}_2) = \{\varepsilon_{z_2}(\mathbf{x}_s, \mathbf{x}_2, \mathbf{y}_2)\}, \quad (18b)$$

$$\mathbf{F}_{y_{21}}(\mathbf{x}_s, \mathbf{x}_2, \mathbf{y}_2) = \{F_{y_{21}}(\mathbf{x}_s, \mathbf{x}_2, \mathbf{y}_2)\} = x_1 x_4 + x_4^2 + x_5 + y_{21} \quad (18c)$$

$$\mathbf{F}_{z_2}(\mathbf{x}_s, \mathbf{x}_2, \mathbf{y}_2) = \{F_{z_2}\} = \sqrt{x_1} + x_4 + x_5(0.4y_{21}) \quad (18d)$$

It is assumed that both the parameter and model error uncertainties follow normal distributions. For all the design variables x_1 to x_5 , their standard deviations are proportional to the means, i.e., $\sigma_{x_i} = 0.1 \mu_{x_i}$, $i = 1, 5$. The model errors, represented by $\boldsymbol{\varepsilon}_{y_{12}}$, $\boldsymbol{\varepsilon}_{y_{21}}$, $\boldsymbol{\varepsilon}_{z_1}$, and $\boldsymbol{\varepsilon}_{z_2}$,

have 0 as the means, and the standard deviations being proportional to function values, i.e, 0.1 times the function values.

Accuracy and efficiency for design evaluations

Means and standard deviations of the system outputs z_1 and z_2 are calculated by the SUA method and the CSSUA method at three arbitrarily selected design points

$(\mu_{x1}, \mu_{x2}, \mu_{x3}, \mu_{x4}, \mu_{x5}) = (1, 1, 1, 1, 1), (2, 2, 2, 2, 2)$ and $(2, 5, 2, 5, 2)$. The results are compared in Table 1.

From Table1, it is seen that at all the three points, means of z_1 and z_2 from the SUA and the CSSUA methods are almost identical to the results from the MCS. The standard deviations of z_1 and z_2 from all the methods are very close with each other. The results from the SUA and the CSSUA are exactly the same which means the suboptimization in the CSSUA generates the same values of the linking variables as the SUA does by solving the set of simultaneous equations. This matches with the discussion in Section 3.2 which states that the SUA and the CSSUA methods are expected to have the same variance if both methods generate the same mean values of linking variables. When applying the CSSUA for this mathematical problem, there are two unknown variables (design variables) in the suboptimization because the number of linking variables is two.

In this example, the number of subsystem $n=2$, the number of output $(N_{y_output}(i) + N_z(i), i = 1, 2)$ is 2 for both subsystems 1 and 2. The number of input $(N_{xs} + N_x(i) + N_{y_input}(i), i = 1, 2)$ is 4 for both subsystems 1 and 2. In terms of the efficiency of our proposed uncertainty analysis method, for the SUA, the number of system level analysis is 1 and the number of subsystem analyses is 28. For the CSSUA, the number of subsystem analyses is 86. The number of system level analysis is 0. These values are

consistent with the derived number of function evaluations presented in Section 3.3. For the MCS, the number of system level analyses is equal to the number of samples used for simulation, which is 10^6 . If the system level analysis involves close-loop iterative subsystem analyses, the total number of subsystem analyses will be multiplications of 10^6 .

Accuracy and efficiency for robust design

For this example, the optimization model without uncertainty is represented as:

$$\begin{aligned}
 &\text{Find: the values of } x_1 \text{ to } x_5 \\
 &\text{Minimize: } z_2 \\
 &\text{Subject to: } 11 - z_1 \leq 0 \\
 &\qquad\qquad\qquad 12 - z_2 \leq 0
 \end{aligned} \tag{19}$$

When considering uncertainty, the optimization model is converted to a robust design model as:

$$\begin{aligned}
 &\text{Find: the mean values } \mu_{x1} \text{ to } \mu_{x5} \\
 &\text{Minimize: } w_1 \frac{\mu_{z2}}{\mu_{z2}^*} + w_2 \frac{\sigma_{z2}}{\sigma_{z2}^*} \text{ (objective)} \\
 &\text{Subject to: } 11 - (\mu_{z1} + k\sigma_{z1}) \leq 0 \text{ (constraint 1)} \\
 &\qquad\qquad\qquad 12 - (\mu_{z2} + k\sigma_{z2}) \leq 0 \text{ (constraint 2)} \\
 &\qquad\qquad\qquad 0 \leq \mu_{xi} \leq 10 \quad i=1,5
 \end{aligned} \tag{20}$$

We should note that the use of weighting factors w_1 and w_2 in the above model is a simplistic treatment for multiobjective optimization. More sophisticated methods are presented in our earlier work²⁵. In the above model, k is chosen to be 1 which indicates that with 84.13% probability, the constraint will be satisfied under the assumption that constraint functions are normally distributed. μ_f^* (obtained by $w_1 = 1$ and $w_2 = 0$) and σ_f^{*2} (obtained by $w_1 = 0$ and $w_2 = 1$) are the ideal solutions used to normalize the two aspects in the objective, i.e., optimizing the mean performance and minimizing performance deviations. Table 2 lists the robust design solutions for this multidisciplinary system from using the proposed two methods and the MCS. The modified feasible direction method is used to solve the problem.

The values of the objective and constraints in the last three rows for the SUA and the CSSUA are the results confirmed by the MCS based on the optimal solutions of μ_{x1} to μ_{x5} . Although the solutions of μ_{x1} to μ_{x5} slightly vary from one method to another, we note that the SUA and the CSSUA methods both generate very close optimal solution to that from the MCS, in terms of the value of the objective function and the feasibility.

In terms of the efficiency for robust design, for the SUA, the total number of system level analysis is 31, one for each of the 31 function evaluations of the optimization for robust design; the total number of subsystem analyses is 868. For the CSSUA, the total number of subsystem analyses is 2660 (for 35 function evaluations of system level optimization), while the number of system analysis is 0. When using the MCS, the number of optimization function evaluation is 46 and the total number of system analyses is equal to 46×10^6 .

4.2 Electronic Packaging Problem

Problem statement

The electronic packaging problem is a benchmark multidisciplinary problem comprising the coupling between electronic and thermal subsystems. Component resistances (in electronic subsystem) are affected by operating temperatures in (thermal subsystem), while the temperatures depend on the resistances. The subsystem relationship is demonstrated in Fig. 3. A detailed problem statement is provided at <http://fmad-www.larc.nasa.gov/mdob/MDOB>.

The system analysis consists of the coupled thermal and electrical analyses. The component temperatures calculated in the thermal analysis are needed in the electrical analysis in order to compute the power dissipation of each resistor. Likewise, the power

dissipation of each component must be known in order for the thermal analysis to compute the temperatures.

There are eight input variables x_1 to x_8 , five linking variables $y_6, y_7, y_{11}, y_{12}, y_{13}$, and four system outputs f, h, g_1 and g_2 , where f stands for objective, h and g stands for constraint. The sets of variables and functions in the two subsystems are shown as follows, where $\{\phi\}$ stands for an empty set.

Electronic Analysis: Input variables: $\mathbf{x}_s = \{\phi\}$, $\mathbf{x}_1 = \{x_5, x_6, x_7, x_8\}$

Linking variables: $\mathbf{y}_{21} = \{y_6, y_7\}$ System outputs: $\mathbf{z}_1 = \{f, h, g_1, g_2\}$

Thermal Analysis: Input variables: $\mathbf{x}_s = \{\phi\}$, $\mathbf{x}_2 = \{x_1, x_2, x_3, x_4\}$

Linking variables: $\mathbf{y}_{12} = \{y_{11}, y_{12}, y_{13}\}$ System outputs: $\mathbf{z}_2 = \{\phi\}$

Of the two subsystems, the thermal analysis is more complex, which requires a finite difference solution for the temperature distribution calculation. The remaining equations in the thermal subsystem are solved algebraically. All equations of the electrical system are solved algebraically.

The original electronic packaging problem involves only deterministic analyses where no uncertainty is considered. The detailed deterministic model can be seen in reference 27. To illustrate the proposed uncertainty analysis methods, we assume uncertainties are associated with the input variables x_i ($i = 1, 8$) and the thermal simulation model, both described by normal distributions. The variation coefficient (the ratio of the standard deviation over the mean) of x_i is 0.1. The variation coefficients of the model errors for linking variables y_{11} and y_{12} are also 0.1.

Accuracy and efficiency for design evaluations

The accuracy of the SUA and the CSSUA methods for design evaluations are first compared at two design points with the results from the MCS. The two points are selected arbitrarily following the normal distribution $N(\mu, \sigma)$:

Point 1: x_1 - $N(0.1, 0.01)$, x_2 - $N(0.1, 0.01)$, x_3 - $N(0.1, 0.001)$, x_4 - $N(0.05, 0.005)$, x_5 - $N(100, 10)$, x_6 - $N(0.004, 0.0004)$, x_7 - $N(100, 10)$, x_8 - $N(0.004, 0.00041)$.

Point 2: x_1 - $N(0.08, 0.008)$, x_2 - $N(0.08, 0.008)$, x_3 - $N(0.055, 0.0055)$, x_4 - $N(0.0275, 0.00275)$, x_5 - $N(505, 50.5)$, x_6 - $N(0.0065, 0.00065)$, x_7 - $N(505, 50.5)$, x_8 - $N(0.0065, 0.00065)$.

The modified feasible direction method is used to solve the problem. The results are shown in Table 3. From Table 3, it is noted that the mean values generated by the SUA and the CSSUA methods are very close. Those results under h are small enough to be considered all as zeros. The estimations of standard deviations by using the SUA and the CSSUA are considered to be satisfactory.

In this example, the number of subsystem $n=2$, the number of output ($N_{y_output}(1) + N_z(1)$, $i = 1, 2$) is 6 for subsystem 1 and 3 for subsystem 2. The number of input ($N_{x_s} + N_x(i) + N_{y_input}(i)$, $i = 1, 2$) is 7 for subsystem 1 and 6 for subsystem 2. In terms of efficiency for uncertainty analysis, for the SUA, the number of system analysis is 1 and the number of subsystem analyses is 82. For the CSSUA, the number of subsystem analyses is 125 (for 43 function evaluations of the suboptimization). The number of system analysis is 0. For the MCS, the number of system analyses is equal to the number of random samples used for simulations, which is 10^6 . If the system analysis involves close-loop iterative subsystem analyses, the total number of subsystem analyses will exceed 10^6 for each subsystem.

Accuracy and efficiency for Robust Optimization

The original deterministic optimization model of the electronic packaging problem is represented as:

$$\begin{aligned} \text{Find: } & x_1 \text{ to } x_8 \\ \text{Minimize: } & f \\ \text{Subject to: } & h \leq 0 \\ & g_1 \leq 0 \\ & g_2 \leq 0 \end{aligned} \quad (21)$$

When uncertainties are considered, robust design optimization is formulated as

$$\begin{aligned} \text{Find: the mean values } & \mu_{x1} \text{ to } \mu_{x8} \\ \text{Minimize: } & w_1 \frac{\mu_f}{\mu_f^*} + w_2 \frac{\sigma_f}{\sigma_f^*} \quad (\text{objective}) \\ \text{Subject to: } & \mu_h + k\sigma_h \leq 0 \quad (\text{constraint 1}) \\ & \mu_{g1} + k\sigma_{g1} \leq 0 \quad (\text{constraint 2}) \\ & \mu_{g2} + k\sigma_{g2} \leq 0 \quad (\text{constraint 3}) \end{aligned} \quad (22)$$

The optimum solutions by different methods are listed in Table 4. Similar to the mathematical example presented earlier, the values of the objective and constraints for the SUA and the CSSUA are the results confirmed by the MCS based on the optimal solutions identified by these two techniques.

We note that the SUA and the CSSUA generate optimum solutions that are close to those from the MCS, both in the design variable space and the objective space. The most accurate method is the SUA and the results of the SUA and the CSSUA are slightly different. The results from all the techniques tested are feasible.

In terms of the efficiency for robust optimization, when using the SUA for uncertainty analysis, the total number of system analysis is 58, one for each of the 58 function evaluations in the optimization for robust design; the total number of subsystem analyses is 4756. With the CSSUA, the total number of subsystem analyses is 7502 (for 62 function evaluations of

the system level optimization). With the MCS, the number of system level optimization function evaluation is 64 and the total number of system analyses is equal to 64×10^6 .

5. Discussions and Closure

Two techniques, namely, the system uncertainty analysis (SUA) method and the concurrent subsystem uncertainty analysis (CSSUA) method, are developed for improving the efficiency of uncertainty propagation in simulation-based multidisciplinary design. Both the parameter uncertainty and model (structure) uncertainty are considered in the proposed procedures. Since the proposed techniques are developed for evaluating only the mean and variance of a performance distribution, they are generally applicable for applications where the first two moments of performance distributions are needed, such as in robust design. The examples illustrate that both uncertainty analysis methods are applicable in MDO applications with an acceptable accuracy. Compared to using MCS, both methods can reduce significantly the all-in-one system level analysis. However, depending on many factors such as the number of linking variables and the number of disciplines involved, the effectiveness of these two techniques varies. Considerations should also include the computational needs for subsystem analyses and the all-in-one integrated system analysis. The SUA method needs one analysis at the system level for the evaluation of mean values of linking variables and system output. The accuracy of this evaluation is important because the Taylor approximations used for variance evaluation are expanded at the mean location. The CSSUA employs a suboptimization to evaluate mean values of linking variables where only analyses at the subsystem level are involved. Once mean values of linking variables are obtained, variances of system output are computed only based on analyses at the subsystem level. Overall the SUA method needs fewer subsystem level analyses than the CSSUA method, but more

system level analyses on the other hand. This feature is demonstrated both analytically in Section 3.3 and empirically in Section 4 through the example problems. As noted, the numbers of all-in-one system level analysis and subsystem level analysis are not direct indications of which method is more efficient. The choice of one method over another highly depends on the relative magnitude of the time needed for system level analysis and that for subsystem analysis, and whether parallelization can be accomplished. In general, if the analysis at the system level is computationally expensive (due to the implicit iteration loops among subsystems), analyses at the subsystem level are more affordable, and parallelization is desired, we may use the CSSUA method, and vice versa. In addition to evaluating the total amount of time need, one should also be aware of the mathematical difficulties related to optimization convergence of using the CSSUA method. For example, the CSSUA convergence may be sensitive to the initial values selected for the target means of linking variables. In a recent paper by Alexandrov and Lewis²⁸, comparative properties of collaborative optimization and other approaches to MDO are presented. Although their work is centered on the formulation and computation of multidisciplinary *optimization* instead of uncertainty analysis, their discussions on “decomposition and disciplinary autonomy” can also be used as useful guidelines for us to choose the CSSUA method versus the SUA method. Interested readers should refer to their paper for further details.

It should be noted that significant computational savings are achieved in this work by employing Taylor expansions to reduce the amount of couplings among disciplines in uncertainty analysis. Further, only the first and second moments (mean and variance) are considered for decision-making under uncertainty and no distributions are needed to implement the methods. We note that the proceeding assumptions are acceptable for the two

multidisciplinary robust design problems illustrated in this paper. However, if high accuracy is needed (for example in reliability assessment) or the description of the full distribution of a system output is important, other approaches may be better suited. These approaches are expected to be generally much more computationally expensive. To further extend the proposed uncertainty analysis techniques, we plan to investigate computational procedures that could allow effective sharing between the gradient information obtained for uncertainty analysis and those needed for system level optimization.

Acknowledgement

The support from the NSF/DMII 9896300 is gratefully acknowledged.

References

1. Phadke, M. S., *Quality Engineering using Robust Design*, Prentice Hall, Englewood Cliffs, New Jersey, 1989, pp. 6-11.
2. Ramakrishnan, B. and Rao, S.S., "A Robust Optimization Approach Using Taguchi's Loss Function for Solving Nonlinear Optimization Problems," *Advances in Design Automation*, ASME DE-32-1, 1991, pp. 241-248.
3. Sundaresan, S., Ishii, K. and Houser, D.P, "A Robust Optimization Procedure with Variations on Design Variables and Constraints," *Advances in Design Automation*, ASME DE-Vol. 69-1, 1993, pp. 379-386.
4. Chen, W., Allen, J.K., Mistree, F. and Tsui, K.-L., "A Procedure for Robust Design: Minimizing Variations Caused by Noise Factors and Control Factors," *ASME Journal of Mechanical Design*, Vol. 118, No. 4, 1996, pp.478-485.
5. Du, X. and Chen, W., "Towards a Better Understanding of Modeling Feasibility Robustness in Engineering Design", *ASME Journal of Mechanical Design*, Vol. 122, No. 4, 2000, pp. 357-583.
6. Chen W., Sahai, A, Messac, A., and Sundararaj, G.J., "Exploration of the Effectiveness of Physical Programming for Robust Design", *ASME Journal of Mechanical Design*, Vol. 22, No. 2, pp. 155-163, 2000.
7. Du, X. and Chen, W., "Methodology for Managing the effect of Uncertainty in Simulation-Based Systems Design", *AIAA Journal*, Vol. 38, No. 8, 2000, pp. 1471-1478.

8. Balling, R. J. and Sobieski, J., "An Algorithm for Solving the System-Level Problem in Multilevel Optimization", *Structural optimization*, Vol. 9, No. 3-4, 1995, pp. 168-177.
9. Renaud, J. E., and Tappeta, R. V., "Multiobjective Collaborative Optimization." *ASME Journal of Mechanical Design*, Vol. 119, No. 3, 1997, pp. 403-411.
10. Kroo, I., Altus, S., Braun, R., Gage, P., and Sobieski, I., "Multidisciplinary Optimization Methods for Aircraft Preliminary Design," AIAA Paper 94-4325, *5th AIAA/USAF/NASA/ISSMO symposium*, Panama City Beach, FL, Sep. 1994.
11. Sues, R. H., Oakley, D. R. and Rhodes, G. S., "Multidisciplinary Stochastic Optimization," *Proceedings of the 10th Conference on Engineering Mechanics*, Part 2, Vol. 2, Boulder, CO., May 1995, pp. 934-937.
12. Mavris, D.V, Bandte, O. and DeLaurentis, D.A., "Robust Design Simulation: A Probabilistic Approach to Multidisciplinary Design," *Journal of Aircraft*, Vol. 36, No. 1, 1999, pp. 298-397.
13. Koch, P.N., Simpson, T.W., Allen, J.K., and Mistree F., "Statistical Approximations for Multidisciplinary Design Optimization: The Problem of Size," *Journal of Aircraft*, Vol. 36, No. 1, 1999, pp. 275-286.
14. Batill S., Renaud, J.E., and Gu, X., "Modeling and Simulation in Uncertainty in Multidisciplinary Design Optimization," AIAA Paper 2000-4803, *8th AIAA/USAF/NASA/ISSMO Symposium on Multidisciplinary Analysis and Optimization*, Long Beach, CA, Sept. 2000.
15. Mahadevan, S. and Raghathamachar, P., "Simulation for System Reliability Analysis of Large Structures," *Computers and Structures*, Vol. 77, Nov. 6, 2000, pp. 725-734.
16. Hoybye, Jan A., "Model Error Propagation and Data Collection Design, An Application in Water Quality Modeling," *Water, Air and Soil Pollution*, Vol. 103, No. 1-4, 1998, pp. 101-119.
17. Isukapalli, S.S, and Georgopoulos, P.G., "Stochastic Response Surface Methods (SRSMs) for Uncertainty Propagation: Application to Environmental and Biological Systems," *Risk Analysis*, Vol. 18, No. 3, 1998, pp. 351-363.
18. Wang Cheng, Parametric Uncertainty Analysis for Complex Engineering Systems, Ph.D. Thesis, Jun. 1999, MIT, pp. 53-113.
19. Du, X. and Chen, W., "A Most Probable Point Based Method for Uncertainty Analysis," *Journal of Design and Manufacturing Automation*, Vol.4, No. 1, 2001, pp. 47-66.
20. Gu, X, Renaud, J. E., and Batill, S. M., "An Investigation of Multidisciplinary Design Subject to Uncertainties," AIAA Paper 98-4747, *7th AIAA/USAF/NASA/ISSMO Multidisciplinary Analysis & Optimization Symposium*, St. Louise, Missouri, Sept. 1998.

21. Bloebaum, C. L., Hajela, P. and Sobieszczanski-Sobieski, J., "Non-Hierarchic System Decomposition in Structural Optimization," *Engineering optimization*, Vol. 19, No. 3, 1992, pp.171-186.
22. Manners W., "Classification and Analysis of Uncertainty in Structural System," *Proceedings of the 3rd IFIP WG 7.5 Conference on Reliability and Optimization of Structural Systems*, Berkeley, California, Mar. 1990, pp.251-260.
23. Ayyub, B.M. and Chao R.U., "Uncertainty Modeling in Civil Engineering with Structural and Reliability Applications," *Uncertainty Modeling and Analysis in Civil Engineering*, edited by Ayyub, B.M., 1997, CRC Press, pp. 3-33.
24. Laskey, K. B., "Model Uncertainty: Theory and Practical Implications," *IEEE Transactions on System, Man, and Cybernetics – Part A: System and Human*, Vol 26, No. 3, 1996, pp 340-348.
25. Apostolakis, G., "A Commentary on Model Uncertainty," *Model Uncertainty: Its Characterization and Quantification*, edited by Mosleh, A, Siu, N, Smidts, C. and Lui, C, NUREG/CP-0138, 1994, U.S. Nuclear Regulatory Commission, pp. 13-22.
26. Chen. W., Wiecek, M., and Zhang, J., "Quality Utility: A Compromise Programming Approach to Robust Design", *ASME Journal of Mechanical Design*, Vol. 121, No. 2, 1999, pp.179-187.
27. Du, X. and Chen, W., "An Efficient Approach to Probabilistic Uncertainty Analysis in Simulation-Based Multidisciplinary Design," AIAA Paper: 2000-0423, *38th Aerospace Sciences Meeting and Exhibit*, Reno, NV, Jan. 2000.
28. Alexandrov, N.M. and Lewis, R.M., "Comparative Properties of Collaborative Optimization and Other Approaches to MDO", NASA/CR-1999-209354, ICASE Report No. 99-24, Jul. 1999.

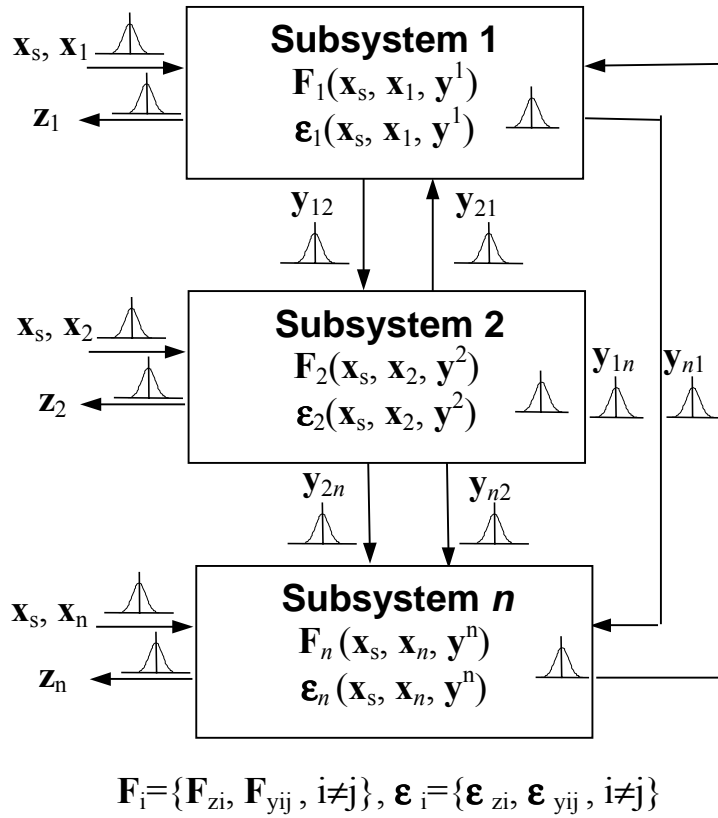

Figure 1 Coupled System

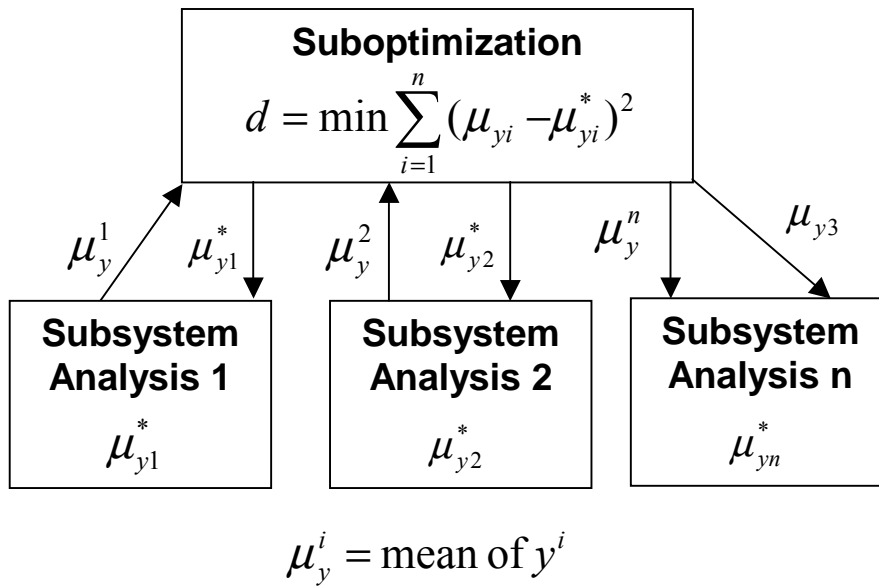

Figure 2 Suboptimization for Uncertainty Analysis in the CSSUA

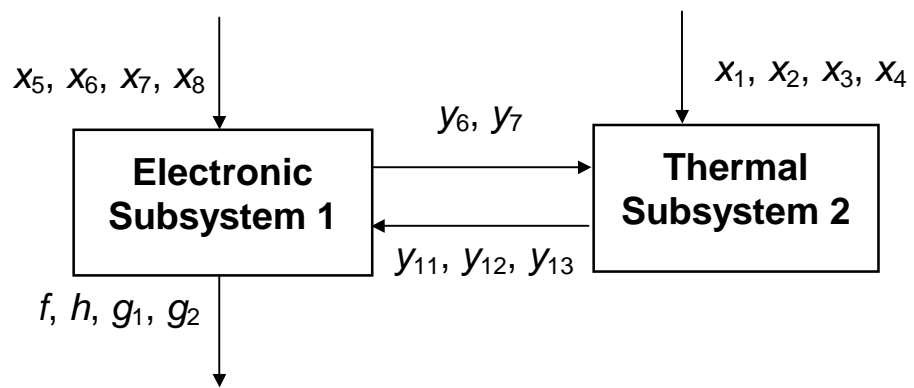

Figure 3 Information Flow - Electronic Packaging Problem

Table 1 Uncertainty analysis result (mathematical problem)

	Method	μ_{z1}	μ_{z2}	σ_{z1}	σ_{z2}
Point 1	SUA	4.0000	3.8870	0.5000	0.4764
	CSSUA	4.0000	3.8870	0.5000	0.4764
	MCS	4.0090	3.8780	0.5018	0.4840
Point 2	SUA	10.0000	8.5130	1.3560	1.1040
	CSSUA	10.0000	8.5130	1.3560	1.1040
	MCS	10.0400	8.5030	1.3580	1.1200
Point 3	SUA	16.0000	13.1200	2.0590	1.6560
	SSUA	16.0000	13.1200	2.0590	1.6560
	MCS	16.0400	13.1100	2.0680	1.6730

Table 2 Robust optimization results of example 1

Method	SUA	CSSUA	MCS
μ_{x1}	2.0700	2.0532	2.1106
μ_{x2}	0.7724	0.9963	1.0104
μ_{x3}	1.8234	1.4822	1.4885
μ_{x4}	0.0001	0.0043	0.1160
μ_{x5}	3.5550	3.4347	3.3227
Objective	4.1859	4.1836	4.1697
Constraint 1	-0.0445	-0.0698	-0.4517
Constraint 2	-0.0423	-0.0369	0.0

Table 3 Means and standard deviations of system output at point 1 (example 2)

	Method	μ_f	σ_f	μ_h	σ_h	μ_{g1}	σ_{g1}	μ_{g2}	σ_{g2}
Point 1	SUA	-1.847×10^3	5.363×10^3	3.901×10^{-6}	1.340×10^{-2}	-44.110	4.046	-44.10	4.390
	CSSUA	-1.847×10^3	5.363×10^3	3.901×10^{-6}	1.340×10^{-2}	-44.110	4.046	-44.10	4.390
	MCS	-1.829×10^3	5.319×10^3	1.0×10^{-11}	1.334×10^{-2}	-44.030	4.137	-44.060	4.130
Point 2	SUA	-1.0180×10^3	1.0490×10^3	1.713×10^{-7}	2.594×10^{-3}	-48.870	3.586	-48.870	3.649
	CSSUA	-1.0180×10^3	1.0490×10^3	1.713×10^{-7}	2.594×10^{-3}	-48.870	3.586	-48.870	3.649
	MCS	-1.0250×10^3	1.0690×10^3	-2.410×10^{-10}	2.663×10^{-3}	-48.850	3.609	-48.880	3.607

Table 4 Optimum results of example 2

Method	SUA	CSSUA	MCS
μ_{x1}	0.1487	0.1402	0.1453
μ_{x2}	0.0634	0.0578	0.0641
μ_{x3}	0.0187	0.0155	0.0148
μ_{x4}	0.0387	0.0336	0.0386
μ_{x5}	1000.0	1000.0	1000.0
μ_{x6}	0.0090	0.0090	0.0090
μ_{x7}	870.6685	875.1554	871.5836
μ_{x8}	0.0089	0.0075	0.0089
Objective	0.3632	0.3656	0.3539
Constraint 1	0.0001	-0.0001	-0.0001
Constraint 2	-45.7486	-45.7289	-45.7576
Constraint 3	-45.6685	-45.6442	-45.7057