

Design and Control of Poppet Type Independently Metering Valves

Sabri Cetinkunt, Professor
Department of Mechanical and Industrial Engineering
University of Illinois at Chicago

A traditional proportional flow control valve has a single spool for each stage to meter flow between pump, tank, two service ports (A, B). One spool geometry defines the orifice areas between the four ports of the valve: pump (P), tank (T), A and B side is of the cylinder. The single variable, spool displacement, determines the orifice areas. These geometric relationships between the spool displacement versus the orifice areas are designed and physically machined into each valve spool. Once the valve is machined, its orifice characteristics are fixed. In order to accommodate many different application specific requirements on orifice shapes, many different spool geometry variations are needed. This requires machining many variations of the basically same spool geometry for different applications. For instance, it has been estimated that one of the major construction equipment manufacturers alone machines over 1700 different valve spool geometries. It would be desirable to reduce the number of different spool geometries that must be physically machined.

This idea had led to the development of *independently metered valve* (IMV) concept. The idea is to define the orifice areas in software by actively and independently actuating each orifice area by a separate spool (Fig.1). As a result, the IMV valve has up to six independently actuated spools, one for each port connection orifice area where each spool position is independently actuated. A single spool EH valve control problem is the control of the position of one spool using an electric motor or a pair of solenoids. An IMV valve control problem involves the control of up to six spool positions independently, hence the control of up to six electric actuators or six pairs of solenoids. Each one of the six metering valves can be implemented as a single orifice spool valve or a poppet valve.

The IMV concept offers the following advantages and disadvantages. The advantages are as follows.

- Valve geometry is defined in software. Therefore, only three or four mechanical valves would be needed to cover the low, medium and high power applications. The application specific spool geometry would be defined in the software.
- Emulated valve geometry in software does not have to be the equivalent of a single mechanical valve. It can function as equivalent of different types of mechanical valve during different operating conditions to optimize the performance.
- Through the added flexibility in valve control, regenerative energy can be used to operate the EH system more energy efficient.

The disadvantages are follows.

- The control component cost is higher and the real time control task is more complicated due to increased number of actuators per valve. While a standard valve has a single electric actuator, an IMV has six electric actuators.
- Because of increased number of electrical components, the number of possible failures is higher.

In this project we pursue the poppet valve approach. Each metering orifice is a poppet valve controlled by an electric actuator (possibly through a pilot stage valve which serves as hydraulic amplifier for the actuation force). A poppet valve has the following main components: a valve body with orifice, a poppet type spool (conical or spherical type) and an actuation mechanism to move the poppet under control (Fig.2). The poppet valve has the following advantages over spool valves: 1) since poppet seats on the orifice parallel to the direction of flow, it seals the orifice leakage free when it is in closed position, 2) it is less sensitive to contamination problems, 3) manufacturing tolerances does not have to be as accurate as spool valves and hence costs less, 4) it can also implement the load-check and relief valve functions in the same hardware. The disadvantages of poppet valves are as follows: 1) since the flow forces acts directly in the direction of poppet motion, the flow forces acting on the valve are unbalanced and makes the dynamic control difficult, 2) the poppet displacement to orifice opening area ratio is large (large gain from poppet

displacement to flow rate change), hence fine flow regulation requires very high resolution and high bandwidth poppet position control.

There are several existing patents on this concept ([1, 2, 3]). This project addresses the following aspects of the IMV valve:

- 1.) compact and modular design of the mechanical and electrical components of the valve (poppet type valve body, six spools, six electric actuators and amplifiers, position and pressure sensors, on board local controller with network capability),
- 2.) real-time control algorithms for the valve that is robust, have guaranteed stability, fail-safe, energy efficient modes in multi function hydraulic circuits for different applications (Fig.3, Fig.4). Also develop sensorless control algorithms using predictive control algorithms (i.e. no position or pressure sensor needed, hence reduced cost).
- 3.) high bandwidth-high force actuator and stable control technology for each poppet spool for large flow rate applications. We study both direct drive and pilot actuated design alternatives for the actuator stage of the poppet valve.

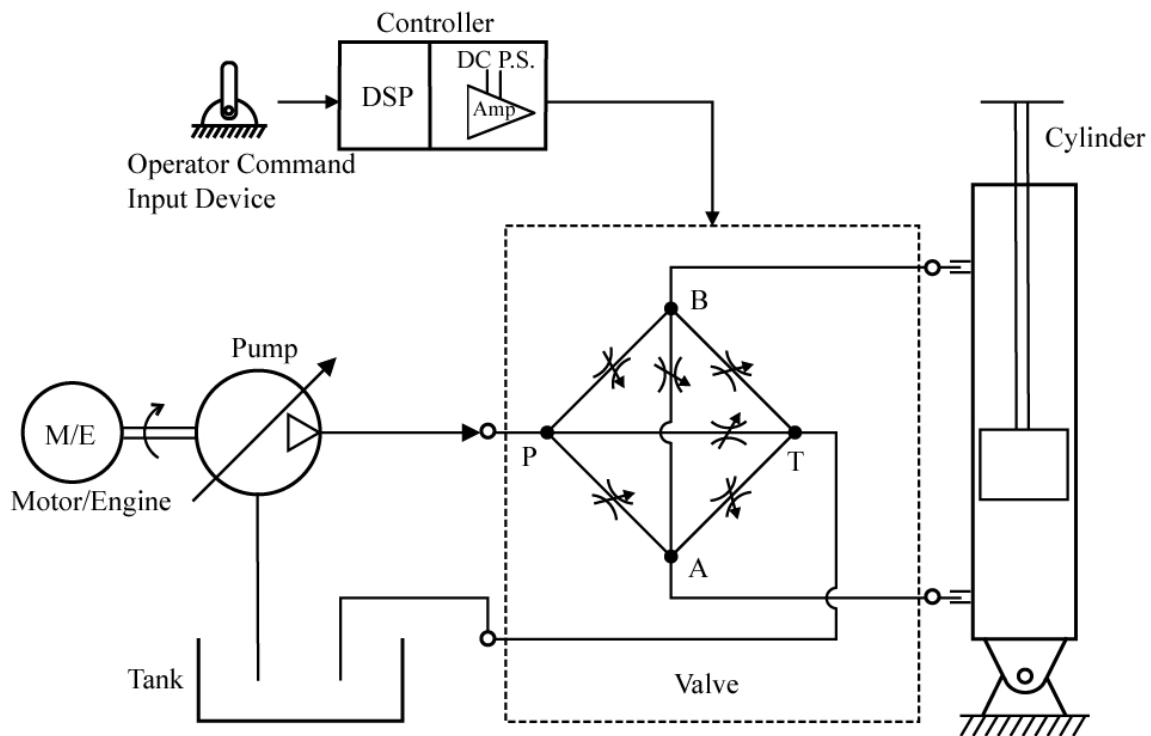

Fig. 1: Independently metered valve (IMV) concept. Each of the six flow orifices of the valve is independently actuated and its metering profile is defined in real-time control software.

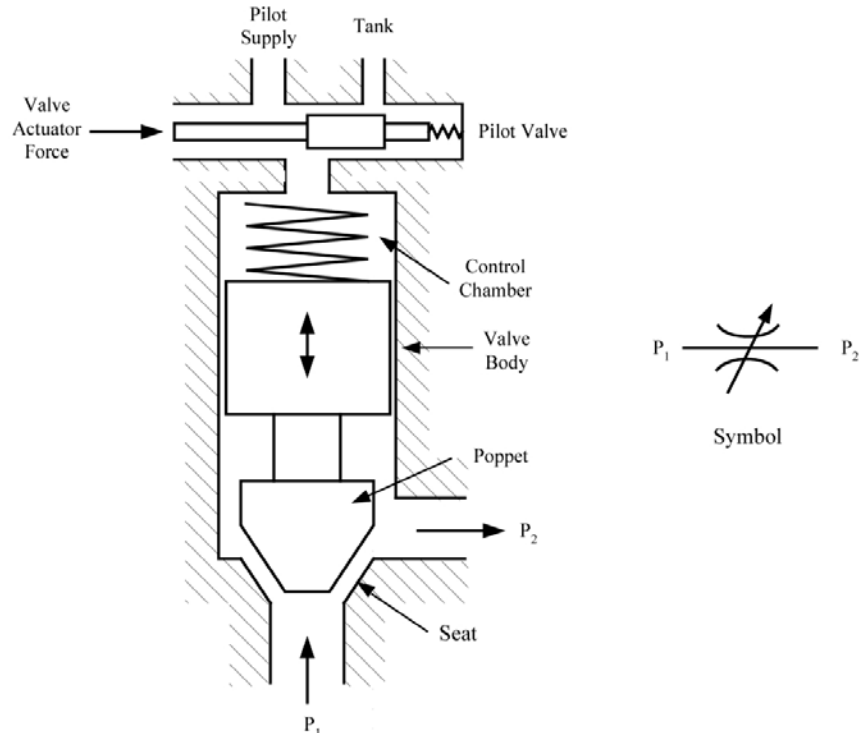

Fig. 2: Poppet valve concept. The main components of the valve are valve body with orifice seat, poppet, and valve actuator. The valve actuator may be direct drive electric motor or an electric actuator plus a pilot valve. One poppet valve is used for each metering section of an IMV.

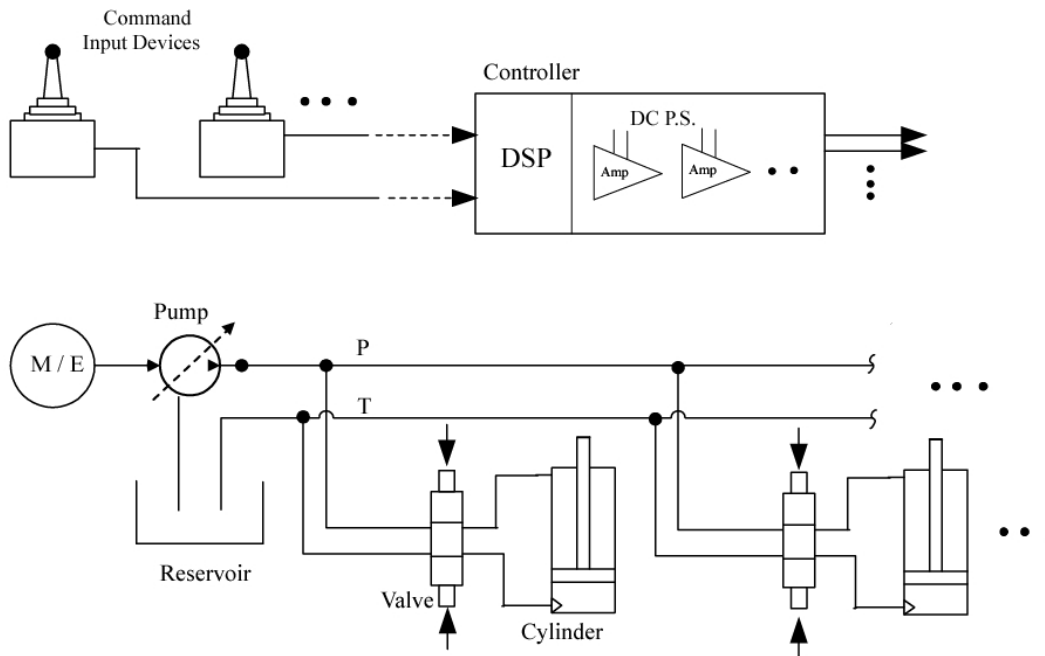

Fig. 3: Multi degrees of freedom (multi function) hydraulic circuit. This example shows a parallel connection of two hydraulic actuator-valve circuits to supply lines. The valves generally need to function like a closed center type in this configuration. Pump is likely to be variable displacement type.

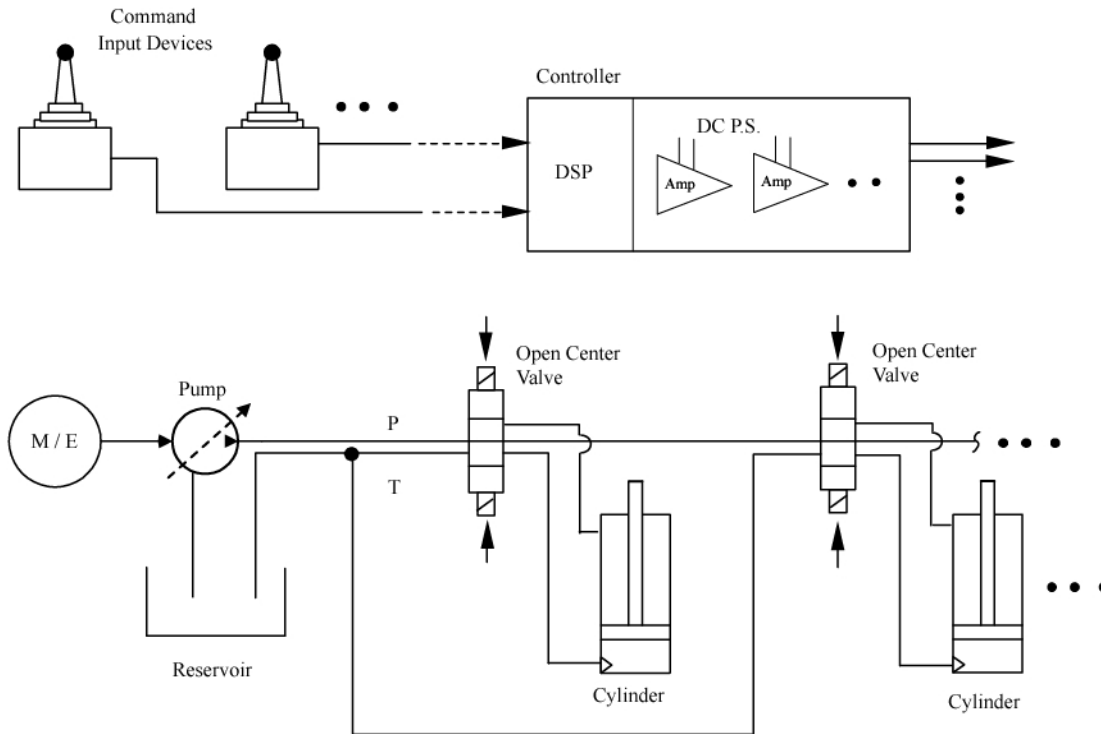

Fig. 4: Multi degrees of freedom (multi function) hydraulic circuit. This example shows a series connection of two hydraulic actuator-valve circuits to supply lines. Valves necessarily need to function like a open-center type in order to supply the circuits in the serial connection when an earlier valve is in neutral position. The valves closer to the pump has priority over the ones that is connected later in the series circuit. Pump can be fixed or variable displacement type.

References:

[1] Aardema, J., Koehler, D., "System and Method for Controlling an Independent Metering Valve", US Patent,
 [2] Garnjost, K., "Energy conserving regenerative flow valves for hydraulic servomotors", US Patent,
 [3] Kramer, K., Fletcher, E., "Electrohydraulic valve system", US Patent, xxxx
 [4] Jansson, A., Palmberg, J. O., "Separate control of meter-in and meter-out orifices in mobile hydraulic systems", ASE Transactions, 99, pp. 337-383.
 [5] Book, R., Goering, C., "Programmable electrohydraulic valve", ASE Transactions, 1999, 108 (2), pp.346-352.
 [6] Hayashi, S., "Instability of Poppet Valve Circuit", JSME International Journal, Series C, Vol 38, No. 3, pp.357-366, 1995.
 [7] Funk, J.E., "Poppet valve stability", Trans. of ASME J. of Basic Engineering, June 1964, pp.207-212.